



02 - 08.2
04.19.GB

SHUT-OFF VALVES

UV 526





UV 526

Shut-off valves

DN 10 - 65
PN 63, 100, 160 and 250

Shut-off valves UV526 are single-seated globe valves designed for shutting off flow of a media. These valves could be optionally equipped with shaped plug for rough control in case of demand. The valve with shaped plug can be permanently partially opened, however, the maximum pressure drop is limited to 5 MPa in this case. The valve seat surface is made with hard metal overlay due to increased service life. The conical shape of the seat in combination with the spherical shape of the plug ensures a high tightness of the closure. The valves UV526 are designed to be actuated with hand wheel or with multi-turn electric actuators and they are available with welded or flanged connection with a sealing surface based on a customer demand. Shut-off valves UV526 according to ČSN EN 13709 (12/2010).

Application

The valves are especially designed for applications in power generation and chemical processing industries. Maximal permissible pressure values depending on choosen material and max. process media temperature are shown on the pg. 7. The maximum operating temperature depends on the material execution.

Installation

The valves with hand wheel can be installed in any position. The valve with electric actuator can be installed in any position except position when the actuator is under the valve body. It is necessary to ensure enough of space for handling. The flow direction is arbitrary except execution with control plug. In case of control plug the flow direction has to be under the plug. It is suitable to insulate the pipeline around the valve but it is prohibited to insulate the valve yoke.

Process media

The valves UV526 are suitable for shutting off water, water vapour and other liquids and gases which are compatible with used materials of the valve body and internal materials.

Technical data											
Series	UV 526										
Execution	Shut-off (Control) valve, single-seated, straight-through, two-way										
Nominal size	DN 10 to 65										
Nominal pressure	PN 63, 100, 160, 250										
Body material (ČSN; EN)	11416	12020	1.0460	15128	1.4571	1.4903	1.5415	1.7335	1.7380	1.7383	1.4541
Operating temperature (from -10°C) to	to 400°C	to 350°C	to 450°C	to 575°C	to 600°C	to 600°C	to 550°C	to 550°C	to 600°C	to 600°C	to 600°C
Seat material	Body material + Stellite 6 overlay										
Plug material	1.4923 + hard metal Real 096										
Yoke material	1.0619			1.7357							
Weld ends connection	Acc. to ČSN EN 12627 (9/2000), ČSN 131075 (03/1991)										
Flange ends connection	Acc. to ČSN EN 1092-1 (7/2014)										
Available types of flanges	Type B1 (raised-face flange); type B2 (plain flange), type C (tongue flange); type D (flange with groove); type E (male flange); typ F (female flange)										
Flow characteristic	on-off, control										
Leakage rate	Class A (On-Off characteristic) acc. to ČSN EN 12266-1 (11/2003) Class D (Control characteristic) acc. to ČSN EN 12266-1 (11/2003)										
Packing	Expanded graphite										

Dimensions and weights of UV 526 with weld ends

DN	H [mm]	L ₁ [mm]	V ₁ [mm]	V ₂ [mm]	V ₃ [mm]	D _{4max} [mm]	K [mm]	D ₅ [mm]	D ₆ [mm]	D ₇ [mm]	D ₈ [mm]	a _p [mm]	n _p	d _p [mm]	m ₁ [kg]
10	12	150	30	252	211	26	200	125	102	70	20	12	8	11	4.0
15	16	160	41	267	226	39	200	125	102	70	20	12	8	11	5.7
20	22	210	60	343	295	54	250	125	102	70	20	12	8	11	12
25	36	250	80	450	381	83	400	175	140	100	30	16	8	17	22
32															
40															
50															
65															

m₁ - approximate weight of the weld ends version

Dimensions of weld ends acc. to ČSN EN 12627 (ČSN 131075), possibly according to the customer's request

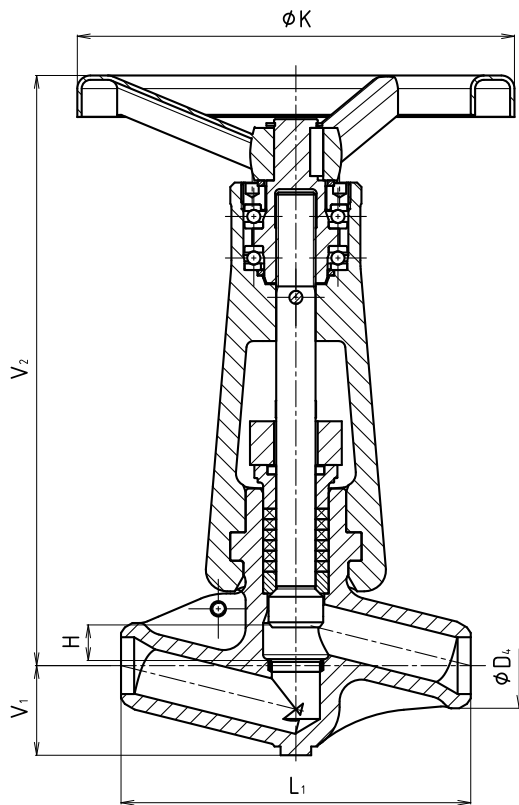

Weld ends version with hand wheel

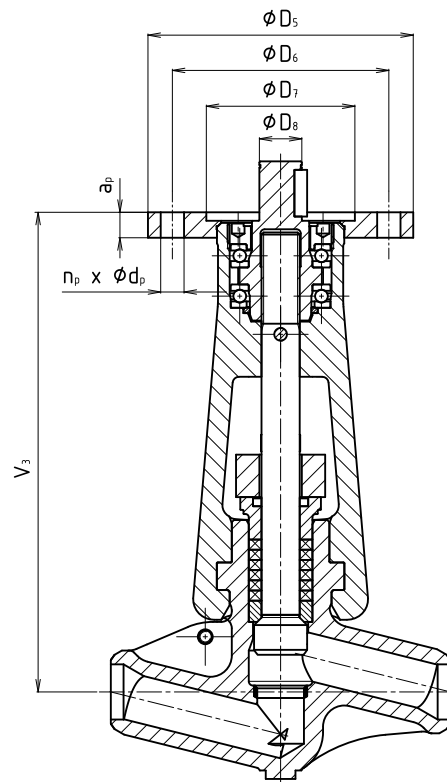

Weld ends version with adjustment for electric actuator

Dimensions and weights of UV 526 with flanges

DN	PN63							PN100							PN160								
	D	D ₁	D ₂	D ₃	a	d	n	D	D ₁	D ₂	D ₃	a	d	n	D	D ₁	D ₂	D ₃	a	d	n		
	[mm]	[mm]	[mm]	[mm]	[mm]	[mm]		[mm]	[mm]	[mm]	[mm]	[mm]	[mm]	[mm]		[mm]	[mm]	[mm]	[mm]	[mm]	[mm]	[mm]	
10	10	100	70	40	20	14	4	10	100	70	40	20	14	4	10	100	70	40	20	14	4		
15	15	105	75	45	20	14	4	15	105	75	45	20	14	4	15	105	75	45	20	14	4		
20	20	130	90	58	22	18	4	20	130	90	58	22	18	4	---	---	---	---	---	---	---		
25	25	140	100	68	24	18	4	25	140	100	68	24	18	4	25	140	100	68	24	18	4		
32	32	155	110	78	26	22	4	32	155	110	78	24	22	4	---	---	---	---	---	---	---		
40	40	170	125	88	26	22	4	40	170	125	88	26	22	4	40	170	125	88	28	22	4		
50	50	180	135	102	26	22	4	50	195	145	102	28	26	4	50	195	145	102	30	26	4		
65	65	205	160	122	26	22	8	65	220	170	122	30	26	8	65	220	170	122	34	26	8		

DN	PN250							PN63-250											PN63-160	PN250		
	D	D ₁	D ₂	D ₃	a	d	n	H	V ₂	V ₃	K	D ₅	D ₆	D ₇	D ₈	a _p	n _p	d _p	m ₂	L ₂	L ₂	
	[mm]	[mm]	[mm]	[mm]	[mm]	[mm]		[mm]	[mm]	[mm]	[mm]	[mm]	[mm]	[mm]	[mm]	[mm]	[mm]	[mm]	[kg]	[mm]	[mm]	
10	10	125	85	40	24	18	4	12	252	211	200								5.5	210	230	
15	15	130	90	45	26	18	4	12	252	211	200								5.7	210	230	
20	---	---	---	---	---	---	---	16	267	226	200	125	102	70	20	12	8	11	9.5	230	---	
25	25	150	105	68	28	22	4	16	267	226	200								10	230	260	
32	---	---	---	---	---	---	---	22	343	295	250									18	260	---
40	40	185	135	88	34	26	4	22	343	295	250								19	260	300	
50	50	200	150	102	38	26	8	36	450	381	400	175	140	100	30	16	8	17	32	300	350	
65	65	230	180	122	42	26	8	36	450	381	400	175	140	100	30	16	8	17	36	340	400	

m₂ - approximate weight with flanges

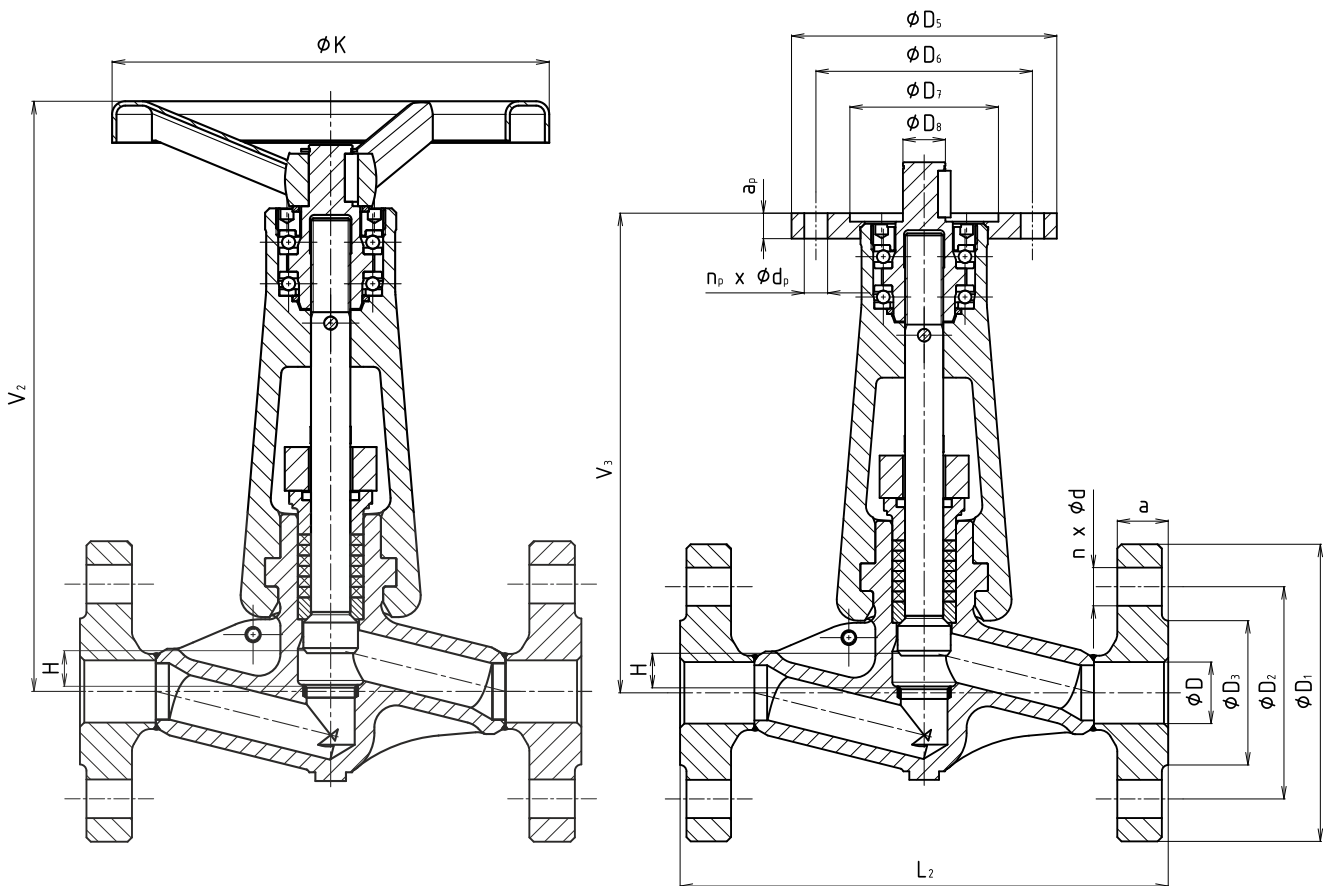

Flanged version with hand wheel

Flanged version with adjustment for electric actuator

Valve complete specification No. for ordering UV 526

		XX	XXX	XXX	XXXX	XX	XXX	/	XXX	-	XXX
1. Valve	Shut-off valve	UV									
2. Series	Shut-off globe valve, forged		526								
3. Type of actuating	Electric actuator			EXX							
	Hand wheel			RXX							
4. Connection	Flanges with raised faces, type B1				1						
	Female flange, type F				2						
	Flanges with plain faces, type B2				3						
	Welded				4						
	Male flange, type E				5						
	Tongue flange, type C				6						
	Flange with groove, type D				7						
5. Body material	Other				9						
	Cast steel 11416 (-10 to 400 °C)				A						
	Cast steel 12020 (-10 to 350 °C)				B						
	Alloy steel 15128 (-10 to 575 °C)				C						
	Cast steel 1.0460 (-10 to 450 °C)				D						
	Stainless steel 1.4571 (-10 to 600 °C)				E						
	Stainless steel 1.4903 (-10 to 600 °C)				F						
	Alloy steel 1.5415 (-10 to 550 °C)				G						
	Alloy steel 1.7335 (-10 to 550 °C)				H						
	Alloy steel 1.7380 (-10 to 600 °C)				I						
	Alloy steel 1.7383 (-10 to 600 °C)				J						
	Stainless steel 1.4541 (-10 to 600 °C)				K						
Other				9							
6. Packing	Grafit				5						
7. Execution	Standard				0						
8. Plug type	Shut-off					0					
	Control					1					
9. Accessories	Without accessories					0					
10. Nominal pressure	PN 63						063				
	PN 100						100				
	PN 160						160				
	PN 250						250				
11. Operating temp. °C	Acc. to operating conditions							/	XXX		
12. Nominal diameter	DN									-	XXX

Order example:

UV526 R20 4B50 00 063/350-025, weld ends acc. to EN 12627-2-DN20, pipe size 26,9 x 2,3

Values of Kvs and pressure loss coefficient z (zeta)

DN	Connection dimension ØB	Loss coefficient of shut-off valve z (zeta)	Kvs value of shut-off valve [m ³ /hod]	Kvs value of control valve [m ³ /hod]
10	10	6,74	1,54	1,53
15	16	6,72	3,95	3,37
20	22	7,20	7,21	5,76
25	26	8,33	9,36	7,02
32	30	7,90	12,8	11,1
40	41	18,6	15,6	14,1
50	52	13,5	29,4	22,5
65	66	35,1	29,4	22,5

Data for an actuator specification

The valves are designed to be actuated with multi-turn electric actuators of the following producers: Auma, Schiebel, ZPA Pečky or others. Actuator connection corresponds ČSN EN ISO 5210, see dimensional sketch on the pg. 3 on this data sheet.

Valves are adjusted with actuators so that in the closed position, i.e. when closing to the seat, the torque switch turns off. In the open position they are adjusted so that the position switch turns off (the torque switch for open position is adjusted as a safety switch to protect the valve against a damage only).

Assigning actuator to valve

DN	Stroke	RPM / stroke	Max. torque	Connection acc. to ČSN EN ISO 5210
	[mm]	[n]	[Nm]	
10 - 15	12	6	20	F10 / type B3
20 - 25	16	8	40	F10 / type B3
32 - 40	22	7,3	80	F10 / type B3
50 - 65	36	6	180	F14 / type B3

Recommended values of output speed (RPM)

DN	Shut-off valve (running time 10 - 20 sec.)	Shut-off valve with ctrl plug (running time 40 - 60 sec.)
	[n/min.]	[n/min.]
10 - 15	18 - 36	6 - 9
20 - 25	24 - 48	8 - 12
32 - 40	22 - 44	7,5 - 11
50 - 65	18 - 36	6 - 9

Actuator marking in valve specification No.

Electric actuator Auma SA 07.2	EAA	Electric actuator SIPOS 2SA70, 2SA73	ETB
Electric actuator Auma SAEx 07.2	EAB	Electric actuator SIPOS 2SA75	ETC
Electric actuator Auma SAR 07.2	EAC	Electric actuator SIPOS 2SA78 HiMod	ETC
Electric actuator Auma SAREx 07.2	EAD	Electric actuator Modact MON/MOP	EYE
Electric actuator Auma SA 07.6	EAE	Electric actuator Modact MON/MOP Control	EYF
Electric actuator Auma SAEx 07.6	EAF	Electric actuator Modact MONED/MOPED	EYF
Electric actuator Auma SAR 07.6	EAG	Electric actuator Modact MONJ	EYE
Electric actuator Auma SAREx 07.6	EAH	Electric actuator Modact MONJ Control	EYF
Electric actuator Auma SA 10.2	EAI	Electric actuator Modact MONEDJ	EYF
Electric actuator Auma SAEx 10.2	EAL	Hand wheel for DN 10 - 25	R20
Electric actuator Auma SAR 10.2	EAJ	Hand wheel for DN 32 - 40	R25
Electric actuator Auma SAREx 10.2	EAK	Hand wheel for DN 50 - 65	R40
Electric actuator Auma SA(R,Ex) 14.2	EAM		
Electric actuator Schiebel AB3	EZA		
Electric actuator Schiebel exAB3	EZB		
Electric actuator Schiebel rAB3	EZC		
Electric actuator Schiebel exrAB3	EZD		
Electric actuator Schiebel AB5	EZE		
Electric actuator Schiebel exAB5	EZF		
Electric actuator Schiebel rAB5	EZG		
Electric actuator Schiebel exrAB5	EZH		
Electric actuator Schiebel AB8	EZI		
Electric actuator Schiebel exAB8	EZJ		
Electric actuator Schiebel rAB8	EZK		
Electric actuator Schiebel exrAB8	EZL		

Maximal permissible pressure values [MPa]

Material	PN	Temperature [°C]											
		100	150	200	250	300	350	400	450	500	550	575	600
Cast steel 11416	63	6.3	6.3	6.3	5.55	4.82	4.13	3.58	---	---	---	---	---
	100	10.0	10.0	10.0	8.81	7.65	6.55	5.68	---	---	---	---	---
	160	16.0	16.0	16.0	14.1	12.2	10.5	9.09	---	---	---	---	---
	250	25.0	25.0	25.0	22.0	19.1	16.4	14.2	---	---	---	---	---
Cast steel 12020	63	6.3	5.82	5.51	5.04	4.56	4.09	---	---	---	---	---	---
	100	10.0	9.25	8.75	8.0	7.25	6.5	---	---	---	---	---	---
	160	16.0	14.8	14.0	12.8	11.6	10.4	---	---	---	---	---	---
	250	25.0	20.5	19.4	17.7	16.1	14.4	---	---	---	---	---	---
Cast steel 15128	63	6.3	6.3	6.3	6.3	6.3	6.3	6.3	6.3	6.3	3.91	2.47	---
	100	10.0	10.0	10.0	10.0	10.0	10.0	10.0	10.0	10.0	6.2	3.91	---
	160	16.0	16.0	16.0	16.0	16.0	16.0	16.0	16.0	16.0	9.92	6.26	---
	250	25.0	25.0	25.0	25.0	25.0	25.0	25.0	25.0	25.0	15.5	9.78	---
Cast steel 1.0460 C22.8, P250GH	63	5.85	5.55	5.25	4.8	4.35	4.05	3.75	2.07	---	---	---	---
	100	9.28	8.8	8.33	7.61	6.9	6.42	5.95	3.28	---	---	---	---
	160	14.85	14.09	13.33	12.19	11.04	10.28	9.52	5.25	---	---	---	---
	250	23.21	22.02	20.83	19.04	17.26	16.07	14.88	8.21	---	---	---	---
Stainless steel 1.4571 X6CrNiMoTi17-12-2	63	6.3	6.09	5.64	5.38	5.12	4.85	4.59	4.41	4.15	3.67	3.39	2.45
	100	10.0	9.66	8.96	8.54	8.12	7.7	7.28	7.0	6.58	5.82	5.39	3.89
	160	16.0	15.46	14.34	13.67	13.0	12.33	11.65	11.21	10.53	9.32	8.62	6.23
	250	25.0	24.16	22.41	21.36	20.31	19.26	18.21	17.51	16.45	14.56	13.47	9.74
Alloy steel 1.4903 X10CrMoVNb9-1	63	6.3	6.3	6.3	6.3	6.3	5.91	5.38	4.97	4.15	3.67	3.52	3.15
	100	10.0	10.0	10.0	10.0	10.0	9.38	8.53	7.89	6.58	5.82	5.59	5.0
	160	16.0	16.0	16.0	16.0	16.0	15.02	13.66	12.62	10.53	9.32	8.94	8.0
	250	25.0	25.0	25.0	25.0	25.0	23.47	21.34	19.72	16.45	14.56	13.97	12.5
Alloy steel 1.5415 15Mo3, 16Mo3	63	6.3	6.16	5.75	5.37	4.99	4.69	4.54	4.2	2.86	1.01	---	---
	100	10.0	9.78	9.12	8.52	7.92	7.44	7.2	6.67	4.53	1.6	---	---
	160	16.0	15.66	14.6	13.64	12.68	11.91	11.53	10.68	7.26	2.56	---	---
	250	25.0	24.46	22.81	21.31	19.81	18.61	18.01	16.68	11.34	4.0	---	---
Alloy steel 1.7335 13CrMo4-5	63	6.3	6.3	6.3	6.3	6.3	5.87	5.38	4.97	3.93	1.85	---	---
	100	10.0	10.0	10.0	10.0	10.0	9.31	8.53	7.89	6.24	2.93	---	---
	160	16.0	16.0	16.0	16.0	16.0	14.91	13.66	12.62	9.99	4.7	---	---
	250	25.0	25.0	25.0	25.0	25.0	23.29	21.34	19.72	15.6	7.34	---	---
Alloy steel 1.7380 10CrMo9-10	63	6.3	6.3	6.3	6.3	6.3	5.91	5.38	4.97	4.15	2.22	2.17	0.94
	100	10.0	10.0	10.0	10.0	10.0	9.38	8.53	7.89	6.58	3.52	3.44	1.49
	160	16.0	16.0	16.0	16.0	16.0	15.02	13.66	12.62	10.53	5.63	5.51	2.39
	250	25.0	25.0	25.0	25.0	25.0	23.47	21.34	19.72	16.45	8.8	8.6	3.73
Alloy steel 1.7383 11CrMo9-10	63	6.3	6.3	6.3	6.3	6.3	5.91	5.38	4.97	4.15	2.22	2.17	0.94
	100	10.0	10.0	10.0	10.0	10.0	9.38	8.53	7.89	6.58	3.52	3.44	1.49
	160	16.0	16.0	16.0	16.0	16.0	15.02	13.66	12.62	10.53	5.63	5.51	2.39
	250	25.0	25.0	25.0	25.0	25.0	23.47	21.34	19.72	16.45	8.8	8.6	3.73
Stainless steel 1.4541 X6CrNiTi18-10	63	5.82	5.47	5.12	4.85	4.59	4.41	4.23	4.06	3.88	3.36	3.28	2.89
	100	9.24	8.68	8.12	7.7	7.28	7.0	6.72	6.44	6.16	5.33	5.2	4.59
	160	14.79	13.89	13.0	12.33	11.65	11.21	10.76	10.31	9.86	8.54	8.32	7.34
	250	23.11	21.71	20.31	19.26	18.21	17.51	16.8	16.1	15.4	13.34	13.0	11.47



LDM, spol. s r.o.
Litomyšlská 1378
560 02 Česká Třebová
Czech Republic

tel.: +420 465 502 511
fax: +420 465 533 101
e-mail: sale@ldm.cz

LDM, spol. s r.o.
Office Prague
Podolská 50
147 01 Praha 4
Czech Republic

tel.: +420 241 087 360
fax: +420 241 087 192
e-mail: sale@ldm.cz

LDM, spol. s r.o.
Office Ústí nad Labem
Ladova 2548/38
400 11 Ústí nad Labem
- Severní Terasa
Czech Republic

tel.: +420 602 708 257
e-mail: tomas.kriz@ldm.cz

LDM servis, spol. s r.o.
Litomyšlská 1378
560 02 Česká Třebová
Czech Republic

tel.: +420 465 502 411-3
fax: +420 465 531 010
e-mail: servis@ldm.cz

LDM Bratislava s.r.o.
Mierová 151
821 05 Bratislava
Slovakia

tel.: +421 2 43415027-8
fax: +421 2 43415029
e-mail: ldm@ldm.sk

LDM, Polska Sp. z o.o.
ul. Bednorza 1
40 384 Katowice
Poland

tel.: +48 32 730 56 33
fax: +48 32 730 52 33
mobile: +48 601 354 999
e-mail: ldmpolska@ldm.cz

LDM Armaturen GmbH
Wupperweg 21
D-51789 Lindlar
Germany

tel.: +49 2266 440333
fax: +49 2266 440372
mobile: +49 177 2960469
e-mail: ldmmarmaturen@ldmvalves.com

OOO "LDM Promarmatura"
Jubilejnyj prospekt,
dom.6a, of. 601
141400 Khimki Moscow Region
Russia

tel.: +7 4957772238
fax: +7 4956662212
mobile: +7 9032254333
e-mail: inforus@ldmvalves.com

TOO "LDM"
Shakirova 33/1
kab. 103
100012 Karaganda
Kazakhstan

tel.: +7 7212 566 936
fax: +7 7212 566 936
mobile: +7 701 738 36 79
e-mail: sale@ldm.kz

LDM - Bulgaria - OOD
z. k. Mladost 1
bl. 42, floor 12, app. 57
1784 Sofia
Bulgaria

tel.: +359 2 9746311
fax: +359 2 9746311
mobile: +359 888 925 766
e-mail: ldm.bg@ldmvalves.com

www.ldmvalves.com

LDM reserves the right to modify or improve the designs or specifications of such products at any time without notice.

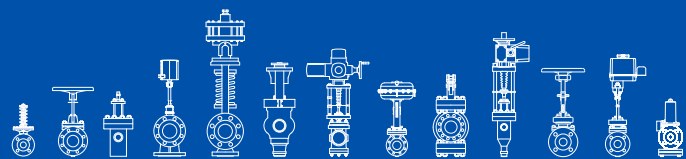

POWER THROUGH IDEAS