



02 - 09.4
05.20.GB

CONTROL AND SHUT-OFF VALVES IN SEISMIC VERSION

300 line

acc. to ANSI/ASME

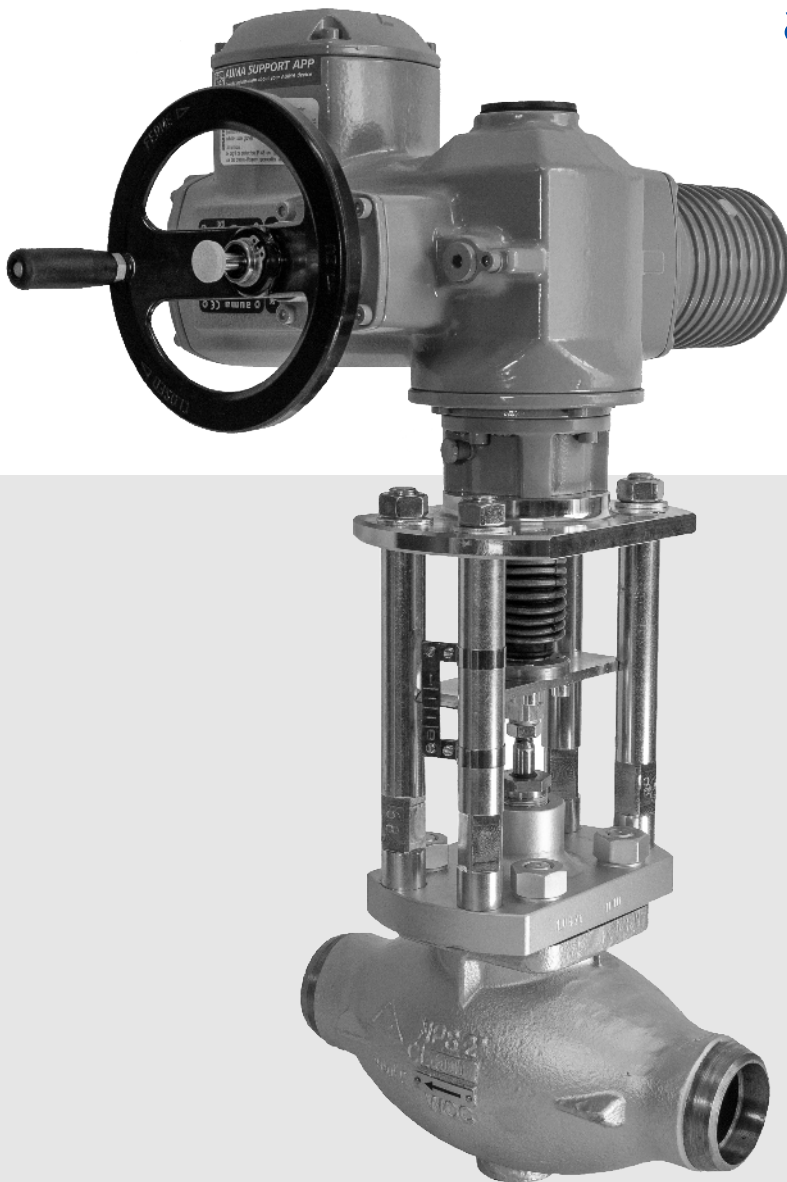

300 line

CV / SV 320 SP (Ex)
CV / SV 330 SP (Ex)

single-seated,
control (shut-off) valve

CV 322 SP (Ex)
CV 332 SP (Ex)

single-seated,
control valve with
pressure-balanced plug

Control (shut-off) **CV / SV 300 line in seismic version** are designed for regulation and shut-off of process liquid flow, for which seismic resistance of the device is required. The valves meet the conditions of **seismic resistance** in the sense of maintaining mechanical integrity and functionality after a seismic event with a response spectrum of up to 30 m.s^{-2} in all directions, in the band 0 to 33 Hz. Thus, they meet the requirements of **seismic classification 1b of fittings for nuclear energy according to OTT 87/91** and in non-nuclear applications meet the conditions for use in earthquake-prone areas with a maximum intensity of up to 9 degrees of the international scale EMS-98, or MSK-64 (9 bal).

In Ex proof version meet the requirements II 1/2G IIC T6...T1 Ga/Gb acc. to ČSN EN ISO 80079-36 (9/2016) and ČSN EN 1127-1 ed.2 (1/2012).

The selected materials correspond to the recommendations acc. to ČSN EN 12516-1 (8/2015). The maximal permissible operating pressures in behaviour with types of material and temperature are specified in the table on page 24 of this catalogue.

Control

hand wheel
seismically resistant electromechanical actuators **Auma**, or other manufacturers

Application

CV / SV 3xx SP - heating, ventilation, power generation and chemical processing industries
CV / SV 3xx SPEx - gas and chemical industries

Process media

liquids, gases and vapours without abrasive particles
e.g. water, steam, air and other media compatible with material of the valve inner parts

To ensure a reliable regulation, the producers recommends to pipe a strainer in front of the valve into pipeline or ensure in any other way that process medium does not contain abrasive particles or impurities

Installation

The valve can be installed in any position except position when the actuator is under the valve body. The valve is to be piped the way so that the direction of medium flow will coincide with the arrows on the body.

It is necessary to protect the actuator from excessive heat from the pipeline at medium **temperatures** above **150 °C (300 °F)**, e.g. by appropriately insulating the pipeline and valve and tilting the actuator from the vertical axis. Detailed informations are given in the instruction for installation and service.

Packings

DRSpack® (PTFE)

DRSpack® (Direct Radial Sealing Pack) is a packing with high tightness at both low and high operating pressure values.

It is the most used type of packing suitable for temperatures ranging from 0 °C to 260 °C. The pH range is from 0 to 14. The packing enables using of actuators with low linear force. The design enables an easy change of the whole packing. The average service life of DRSpack® is more than 500 000 cycles.

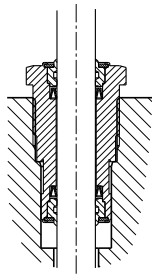

Graphite

This type of packing can be used for media **with temperature up to 550 °C (1020 °F)** and pH range: 0 to 14. Packing can be "sealed up" either by screwing the packing screw in or adding another sealing ring. In regard of intensive frictional forces, graphite packing is suitable for actuators with a sufficient linear force.

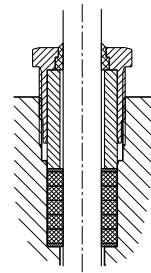

Principles for plug type selection

V-ported plugs should not be used in supercritical differential pressures with inlet pressure $p \geq 0,4$ MPa and for regulation of saturated steam. In these cases we recommend to use a perforated plug. The perforated plug should be also used always when cavitation may occur due to a high differential pressure value or valve ports erosion caused by high speed of process medium flow. If the parabolic plug is used (because of small Kvs) for supercritical differential pressures, it is necessary to close both plug and seat with a hard metal overlay, i.e. stellite trim.

Rangeability

Rangeability is the ratio of the biggest value of flow coefficient to the smallest value. In fact it is the ratio (under the same conditions) of highest regulated flow rate value to its lowest value. The lowest or minimal regulated flow rate is always higher than 0.



CV/SV 3x0 SP

Control
and shut-off valves
in seismic version

**NPS 1/2" - 16",
Class 150, 300 and 600**

Technical data

Series	CV / SV 320 (Ex)	CV / SV 330 (Ex)
Type of valve	Two-way, single-seated, control (shut-off) valve	
Nominal size range	NPS 1/2" - 16"	
Nominal pressure	Class 300 and 600 (Class 150, 300 and 600 (weld ended))	
Body material	Cast steel A216 WCB, A217 WC6	Stainless steel A351 CF8M
Seat material:	NPS 1/2" - 2" 1.4028	1.4571
DIN W.Nr./+ČSN	NPS 3" - 16" 1.4027	1.4581
Plug material:	NPS 1/2" - 2" 1.4021	1.4571
DIN W.Nr./+ČSN	NPS 3" - 16" 1.4027	1.4581
Stem material	1.4923	1.4980
Operating temperature range	-50 to 550 °C (-58 to 1020 °F) - (the negative temperature requirement must be specified in the order)	
Face to face dimensions	Acc. to ISA-75.08.01-2002 (R2007) for version with flanges Acc. to ISA-75.08.03-2001 (R2007) for weld ends - version Socket Weld Acc. to ISA - 75.08.05-2002 (R2007) for weld ends - version Butt Weld	
Connection flanges	Acc. to ČSN EN 1092-1+A1 (7/2013)	
Flange faces	Type B1 (raised-faced) or Type B2 (plain face) or Type F (female), or Type D (groove) acc. to ČSN EN 1092-1+A1 (7/2013)	
Weld ends	Weld ends acc. to ČSN EN 12627-2 (8/2000)	
Type of plug	V-ported, contoured, perforated	
Flow characteristic	Linear, equal-percentage, LDMspline®, parabolic, on - off	
Kvs value	0.01 to 1600 m ³ /h	
Leakage rate	Class III. acc. to ČSN-EN 1349 (7/2010) (<0.1% Kvs) for c. valves with metal-metal seat sealing Class IV. acc. to ČSN-EN 1349 (7/2010) (<0.01% Kvs) for shut off valve Class IV. acc. to ČSN EN 1349 (7/2010) (<0.01% Kvs) pro uzavírací ventil	
Leakage rate for Ex version	CV 3xx class IV. acc. to ANSI/FCI 70-2-2013 (< 0.01% Kvs); SV 3xx step C acc. to ISO 5208:2008	
Rangeability r	50 : 1	
Packing	DRSpack® (PTFE) t _{max} = 260 °C (500°F), Expanded graphite t _{max} = 550 °C (1020°F), Bellows (DN15-150) t _{max} = 550°C (1020°F)	
Seismic resistance	0 to 33 Hz, 30 m.s ⁻²	

Cv (Kvs) values and differential pressures Δp_{max} [MPa], [psi] of valves NPS 1/2" - 16" with countoured and V-ported plugs flow direction below plug with electro-mechanic actuators

Δp_{max} value is the valve max. differential pressure when max open - close function is always guaranteed.

Differential pressure must not exceed 2,0 MPa (290 psi) for valves Class 150 and 5,0 MPa (750 psi) for valves Class 300. In regard of service life of seat and plug, it is recommended so that permanent differential pressure would not exceed 1.6 MPa / 232 psi. Otherwise it is suitable to use perforated plug (Δp up to 4,0 MPa / 580 psi) or sealing surfaces of seat and plug with a hard metal overlay (Δp up to 2,5 MPa / 363 psi).

For further information on actuating, see actuators' catalogue sheets			Actuating (actuating)										Auma		Auma		Auma		Hand wheel	
			Marking in valve specification No.										EA...		EA...		EA...		Rxx	
			Linear force										5 kN		7.5 kN		10 kN			
NPS	H[mm]	Ds[mm]	Kvs [m³/h] Cv [US gallon/min]										Δp_{max} [MPa] [psi]		Δp_{max} [MPa] [psi]		Δp_{max} [MPa] [psi]		Δp_{max} [MPa] [psi]	
			1	2	3	4	5	6	7	8	9		graphite	PTFE	graphite	PTFE	graphite	PTFE	graphite	PTFE
1/2"	16	3	---	---	---	---	---	---	---	0.16 ³⁾	0.1...0.01 ³⁾		10	10	10	10	10	10	10	10
		6	---	---	---	---	---	---	0.25 ¹⁾	0.18 ³⁾	0.116...0.012 ³⁾		1450	1450	1450	1450	1450	1450	1450	1450
		8	---	---	---	1.0 ¹⁾	0.63 ¹⁾	0.4 ¹⁾	---	---	---	---	10	10	10	10	10	10	10	10
		12	---	2.5 ¹⁾	1.6 ¹⁾	---	---	---	---	---	---	---	6.42	10	10	10	10	10	10	10
		15	4.0 ¹⁾	---	---	---	---	---	---	---	---	---	8.91	10	10	10	10	10	10	10
1"	16	3	---	---	---	---	---	---	---	---	0.16...0.01 ³⁾		10	10	10	10	10	10	10	10
		6	---	---	---	---	---	---	---	0.25 ¹⁾	0.18...0.012 ³⁾	1450	1450	1450	1450	1450	1450	1450	1450	1450
		8	---	---	---	---	---	1.0 ¹⁾	0.63 ¹⁾	0.4 ¹⁾	---	---	10	10	10	10	10	10	10	10
		12	---	---	---	2.5 ¹⁾	1.6 ¹⁾	---	---	---	---	---	6.42	10	10	10	10	10	10	10
		15	---	---	4.0 ¹⁾	---	---	---	---	---	---	---	8.91	10	10	10	10	10	10	10
		20	---	6.3 ²⁾	---	---	---	---	---	---	---	---	4.33	10	10	10	10	10	10	10
		25	10.0	6.3 ⁴⁾	4.0 ⁴⁾	---	---	---	---	---	---	---	2.59	6.48	7.16	10	10	10	10	10
1 1/2"	16	6	---	---	---	---	---	---	---	---	0.25 ¹⁾	10	10	10	10	10	10	10	10	
		8	---	---	---	---	---	---	1.0 ¹⁾	0.63 ¹⁾	0.4 ¹⁾	0.29 ¹⁾	1450	1450	1450	1450	1450	1450	1450	1450
		12	---	---	---	---	2.5 ¹⁾	1.6 ¹⁾	---	---	---	---	6.42	10	10	10	10	10	10	10
		15	---	---	---	---	4.0 ¹⁾	---	---	---	---	---	8.91	10	10	10	10	10	10	10
		20	---	---	---	---	6.3 ²⁾	---	---	---	---	---	4.33	10	10	10	10	10	10	10
		40	25	16	10	6.3 ⁴⁾	4.0 ⁴⁾	---	---	---	---	---	0.90	2.42	2.68	4.19	4.45	5.97	4.45	5.97
2"	20	50	40	25	16	10	6.3 ⁴⁾	---	---	---	---	0.50	1.40	1.56	2.47	2.63	3.53	2.63	3.53	

the table continues on the next page

¹⁾ parabolic plug

²⁾ V-ported plug with linear characteristic, parabolic plug with equal-percentage and LDMspline®

³⁾ valve with micro-throttling trim. Execution with Kvs = 0,16; 0,1; 0,063; 0,04; 0,025; 0,016; 0,01

(Cv = 0,18; 0,11; 0,073; 0,046; 0,029; 0,018; 0,011)

⁴⁾ V-ported plug with linear characteristic only

For further information on actuating, see actuators' catalogue sheets			Actuating (actuating)					Auma		Auma		Auma		Auma		Auma		Hand wheel	
			Marking in valve spec. No.					EA...		EA...		EA...		EA...		EA...		Rxx	
			Linear force					7.5 kN		10 kN		15 kN		20 kN		32 kN			
			Kvs [m ³ /h] Cv [US galon/min]					Δp _{max} [MPa] [psi] packing		Δp _{max} [MPa] [psi] packing		Δp _{max} [MPa] [psi] packing		Δp _{max} [MPa] [psi] packing		Δp _{max} [MPa] [psi] packing		packing	
NPS	H[mm]	Ds[mm]	1	2	3	4	5	graphite	PTFE	graphite	PTFE	graphite	PTFE	graphite	PTFE	graphite	PTFE	graphite	PTFE
3"	40	80	100	63	40	25	16	0.28	0.73	0.73	1.18	1.63	2.08	2.53	2.98	---	---	1.81	2.26
			116	72.8	46.2	28.9	18.5	41	106	106	171	236	302	367	432	---	---	263	328
4"	40	100	160	100	63	40	25	0.16	0.45	0.45	0.74	1.03	1.32	1.62	1.91	---	---	1.15	1.44
			185	116	72.8	46.2	28.9	23	65	65	108	150	192	234	277	---	---	167	209
6"	40	150	360	250	160	100	63	0.05	0.18	0.18	0.31	0.44	0.58	0.71	0.84	---	---	0.50	0.63
			416	289	185	116	72.8	7	26	26	45	64	83	103	122	---	---	72	91
8"	80	100	---	---	250	160	100	---	---	---	---	0.85	1.19	1.44	1.79	2.87	3.21	3.81	4.15
			---	---	289	185	116	---	---	---	---	124	173	210	259	416	465	553	602
			---	400	---	---	---	---	---	---	---	0.36	0.51	0.62	0.78	1.27	1.42	1.69	1.85
8"	80	150	---	462	---	---	---	---	---	---	---	52	74	91	113	183	206	245	268
			570	---	---	---	---	---	---	---	0.19	0.28	0.34	0.43	0.70	0.79	0.95	1.03	
			659	---	---	---	---	---	---	---	27	40	49	62	102	115	137	150	
10"	80	150	---	---	400	250	160	---	---	---	---	0.21	0.39	0.48	0.66	1.13	1.31	1.56	1.74
			---	---	462	289	185	---	---	---	---	31	56	70	96	164	190	227	252
			---	630	---	---	---	---	---	---	0.11	0.20	0.26	0.36	0.62	0.72	0.87	0.97	
10"	80	200	---	728	---	---	---	---	---	---	---	15	30	37	52	91	105	126	141
			800	---	---	---	---	---	---	---	0.07	0.15	0.19	0.26	0.47	0.54	0.65	0.73	
			925	---	---	---	---	---	---	---	11	21	27	38	68	79	95	106	
12"	80	150	---	---	---	400	250	---	---	---	---	0.21	0.39	0.48	0.66	1.13	1.31	1.56	1.74
			---	---	---	462	289	---	---	---	---	31	56	70	96	164	190	227	252
			---	---	630	---	---	---	---	---	0.11	0.20	0.26	0.36	0.62	0.72	0.87	0.97	
			---	728	---	---	---	---	---	---	15	30	37	52	91	105	126	141	
12"	80	200	---	---	800	---	---	---	---	---	---	0.07	0.15	0.19	0.26	0.47	0.54	0.65	0.73
			---	925	---	---	---	---	---	---	11	21	27	38	68	79	95	106	
			1000	---	---	---	---	---	---	---	0.06	0.12	0.16	0.22	0.39	0.46	0.55	0.61	
			1160	---	---	---	---	---	---	8	18	23	32	57	66	80	89		
16"	100	150	---	---	---	400	250	---	---	---	---	0.21	0.39	0.48	0.66	1.13	1.31	1.56	1.74
			---	---	---	462	289	---	---	---	---	31	56	70	96	164	190	227	252
			---	---	630	---	---	---	---	---	0.11	0.20	0.26	0.36	0.62	0.72	0.87	0.97	
			---	728	---	---	---	---	---	---	15	30	37	52	91	105	126	141	
16"	100	250	---	---	1000	---	---	---	---	---	---	0.06	0.12	0.16	0.22	0.39	0.46	0.55	0.61
			---	1160	---	---	---	---	---	---	8	18	23	32	57	66	80	89	
			1600	---	---	---	---	---	---	---	0.02	0.06	0.08	0.12	0.22	0.25	0.31	0.35	
			1850	---	---	---	---	---	---	4	9	12	17	32	37	45	50		

Cv (Kvs) values and differential pressures Δp_{max} [MPa], [psi] of valves NPS 1/2" - 16" with perforated plugs (flow direction above plug) for electro-mechanical actuators

Δp_{max} value is the valve max. differential pressure when max open - close function is always guaranteed. Differential pressure must not exceed 2,0 MPa (290 psi) for valves Class 150 and 5,0 MPa (750 psi) for valves Class 300. In regard of service life of seat and plug, it is recommended so that permanent differential pressure of the valves with perforated plug is limited to max. 4,0 MPa / 580 psi.

For further information on actuating, see actuators' catalogue sheets			Actuating (actuating)					Auma		Auma		Auma		Auma		Auma		Auma		Hand wheel	
			Marking in valve spec. No.					EA...		EA...		EA...		EA...		EA...		EA...		Rxx	
			Linear force					5 kN		7.5 kN		10 kN		15 kN		20 kN		32 kN			
			Kvs [m ³ /h]					Δp_{max} [MPa]		Δp_{max} [MPa]		Δp_{max} [MPa]		Δp_{max} [MPa]		Δp_{max} [MPa]		Δp_{max} [MPa]			
			Cv [US galon/min]					packing		packing		packing		packing		packing		packing		packing	
NPS	H[mm]	Ds[mm]	1	2	3	4	5	graphite	PTFE	graphite	PTFE	graphite	PTFE	graphite	PTFE	graphite	PTFE	graphite	PTFE	graphite	PTFE
1"	16	25	---	6.3	4.0	2.5 ⁵⁾	1.6 ⁵⁾	2.59	6.48	7.16	10.0	10.0	10.0	---	---	---	---	---	---	10	10
				7.28	4.62	2.89⁵⁾	1.85⁵⁾	376	940	1038	1450	1450	1450								1450
1½"	40	40	---	16	10	6.3	4.0	0.90	2.42	2.68	4.19	4.45	5.97	---	---	---	---	---	---	4.45	5.97
				18.5	11.6	7.28	4.62	131	350	388	608	646	866								646
2"	20	50	---	25	16	10	6.3	0.50	1.40	1.56	2.47	2.63	3.53	4.75	5.66	---	---	---	---	2.63	3.53
				28.9	18.5	11.6	7.28	72	204	226	358	381	512	689	821						381
3"	80	80	---	63	40	25	16	---	---	0.28	0.73	0.73	1.18	1.63	2.08	2.53	2.98	---	---	1.81	2.26
				72.8	46.2	28.9	18.5			41	106	106	171	236	302	367	432				263
4"	40	100	---	100	63	40	25	---	---	0.16	0.45	0.45	0.74	1.03	1.32	1.62	1.91	---	---	1.15	1.44
				116	72.8	46.2	28.9			23	65	65	108	150	192	234	277				167
6"	150	150	---	250	160	100	63	---	---	0.05	0.18	0.18	0.31	0.44	0.58	0.71	0.84	---	---	0.50	0.63
				289	185	116	72.8			7	26	26	45	64	83	103	122				72
8"	200	200	---	400	250	160	100	---	---	---	---	---	---	0.19	0.28	0.34	0.43	0.70	0.79	0.95	1.03
				462	289	185	116								27	40	49	62	102	115	137
10"	80	230	---	630	400	250	160	---	---	---	---	---	---	0.07	0.15	0.19	0.26	0.47	0.54	0.65	0.73
				728	462	289	185								11	21	27	38	68	79	95
12"	250	250	---	800	630	400	250	---	---	---	---	---	---	0.06	0.12	0.16	0.22	0.39	0.46	0.55	0.61
				925	728	462	289								8	18	23	32	57	66	80
16"	100	330	---	1000	630	400	250	---	---	---	---	---	---	0.02	0.06	0.08	0.12	0.22	0.25	0.31	0.35
				1160	728	462	289								4	9	12	17	32	37	45

⁵⁾ linear characteristic only

Dimensions and weights of valves CV / SV 320 SP (Ex) CV / SV 330 SP (Ex) with flanges and weld ends, NPS 1/2" - 16"

NPS	H	V ₂	V ₃	V ₄	ØD ₅	M	ØD ₆	V ₅	m ₁	m ₂	Class 300			Class 600			Class 150 - 600
											L ₁			L ₁			L ₂
											RF	RTJ	LFF SFF LGF SGF	RF	RTJ	LFF SFF LGF SGF	
[mm] [inch]	[mm] [inch]	[mm] [inch]	[mm] [inch]	[mm] [inch]	[mm] [inch]	[mm] [inch]	[mm] [inch]	[mm] [inch]	kg	kg	[mm] [inch]	[mm] [inch]	[mm] [inch]	[mm] [inch]	[mm] [inch]		
1/2"	16 0.63	63 2.480	152 5.984	89 3.504	65 2.559	---	M10x1	47 1.85	7	5	190 7.5	201 7.91	200 7.87	203 8.0	202 7.95	200 7.87	203 8.0
1"		73 2.874	162 6.378					52 2.047	9	6	197 7.75	210 8.25	207 8.15	210 8.25	207 8.15	210 8.25	
1 1/2"		104 4.094	193 7.598					52 2.047	15	8	235 9.25	248 9.76	245 9.64	251 9.88	251 9.88	248 9.76	251 9.88
2"								73 2.874	20 0.787	73 2.874	20	13	267 10.5	283 11.14	277 10.9	286 11.25	289 11.38
3"	40 1.575	139 5.472	245 9.646	106 4.173	---	---	M16x1,5	105 4.133	41	28	318 12.5	332 13.22	328 12.91	337 13.25	340 13.38	334 13.15	337 13.25
4"		105 4.133	67	37				368 14.5	384 15.12	378 14.88	394 15.5	397 15.63	391 15.39	394 15.5			
6"		179 7.047	281 11.063	102 4.016				134 5.275	160	105	473 18.62	489 19.25	483 19.01	508 20.0	511 20.12	505 19.88	508 20.0
8"	80 3.15	262 10.314	422 16.614	160 6.299	---	150 5.905	M20x1,5	203 7.992	280	200	568 22.38	584 22.99	578 22.75	610 24.0	613 24.13	607 24.0	610 24.0
10"		346 13.622	506 19.921					253 9.961	540	370	708 27.88	724 28.5	718 28.27	752 29.62	755 29.72	749 29.49	752 29.62
12"		395 15.551	555 21.85					296 11.654	680	520	775 30.5	791 31.14	785 30.91	819 32.25	822 32.36	816 32.13	819 32.25
16"		512 20.157	672 26.457					382 15.039	1380	1130	1057 41.62	1073 42.24	1067 42.01	1108 43.62	1111 43.74	1105 43.5	1108 43.62

NPS	RF Class 300							RF Class 600							RTJ Class 300 a 600				Groove Number
	ØD ₁	ØD ₂	ØD ₃	d	n	a	b	ØD ₁	ØD ₂	ØD ₃	d	n	a	b	ØD ₇	e	f		
	[mm] [inch]	[mm] [inch]	[mm] [inch]	[mm] [inch]		[mm] [inch]	[mm] [inch]	[mm] [inch]	[mm] [inch]	[mm] [inch]	[mm] [inch]	[mm] [inch]		[mm] [inch]	[mm] [inch]	[mm] [inch]	[mm] [inch]		
1/2"	95 3.75	66.7 2.62	34.9 1.38	15.9 5/8"	4	12.7 0.5	2 0.06	95 3.75	66.7 2.62	34.9 1.38	15.9 5/8"	4	14.3 0.56	7 0.25	34.14 1.344	5.54 0.219	7.14 0.281	R11	
1"	125 4.88	88.9 3.5	50.8 2.0	19.1 3/4"		15.9 0.62		125 4.88	88.9 3.5	50.8 2.0	19.1 3/4"		17.5 0.69		50.8 2.0	6.35 0.25	8.74 0.344	R16	
1 1/2"	155 6.12	114.3 4.5	73 2.88	22.3 7/8"		19.1 0.75		155 6.12	114.3 4.5	73 2.88	22.3 7/8"		22.3 0.88		68.27 2.688	6.35 0.25	8.74 0.344	R20	
2"	165 6.5	127 5.0	92.1 3.62	19.1 3/4"		20.7 0.81		165 6.5	127 5.0	92.1 3.62	19.1 3/4"		25.4 1.0		82.55 3.25	7.92 0.312	11.91 0.469	R23	
3"	210 8.25	168.3 6.62	127 5.0	22.3 7/8"	8	27 1.06	2 0.06	210 8.25	168.3 6.62	127 5.0	22.3 7/8"	8	31.8 1.25	7 0.25	117.48 4.625	7.92 0.312	11.91 0.469	R30	
4"	255 10	200 7.88	157.2 6.19	22.3 7/8"		30.2 1.19		275 10.75	215.9 8.5	157.2 6.19	25.4 1"		38.1 1.5		149.23 5.875	7.92 0.312	11.91 0.469	R37	
6"	320 12.5	269.9 10.62	215.9 8.5	22.3 7/8"	12	35 1.38	2 0.06	320 12.5	269.9 10.62	215.9 8.5	22.3 7/8"	12	47.7 1.88	7 0.25	211.12 8.312	7.92 0.312	11.91 0.469	R45	
8"	380 15	330.2 13.0	269.9 10.62	25.4 1"		39.7 1.56		420 16.5	349.2 13.75	269.9 10.62	31.8 1 1/4"		55.6 2.19		269.9 10.625	7.92 0.312	11.91 0.469	R49	
10"	445 17.52	387.4 15.25	323.8 12.75	28.6 1 1/8"	16	46.1 1.82	2 0.06	445 17.52	387.4 15.25	323.8 12.75	28.6 1 1/8"	16	63.5 2.5	7 0.25	323.85 12.75	7.92 0.312	11.91 0.469	R53	
12"	520 20.47	450.8 17.75	381 15	31.8 1 1/4"		49.3 1.94		560 22.05	489 19.25	381 15	34.9 1 3/8"		66.7 2.63		381 15	7.92 0.312	11.91 0.469	R57	
16"	650 25.59	571.5 22.5	469.9 18.5	34.9 1 3/8"	20	55.6 2.19	685 26.97	603.2 23.75	469.9 18.5	41.3 1 5/8"	76.2 3	469.9 18.5	7.92 0.312	11.91 0.469	R65				

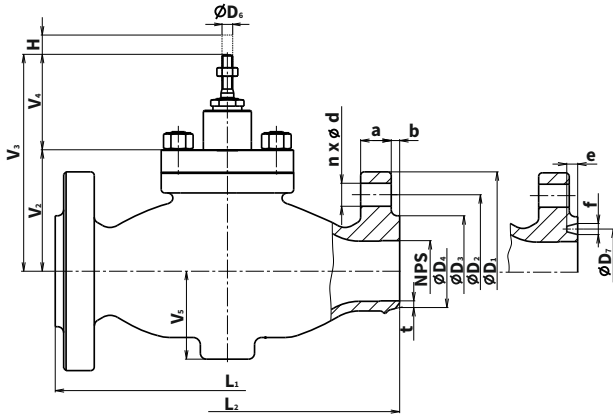

NPS 1/2" - 6"

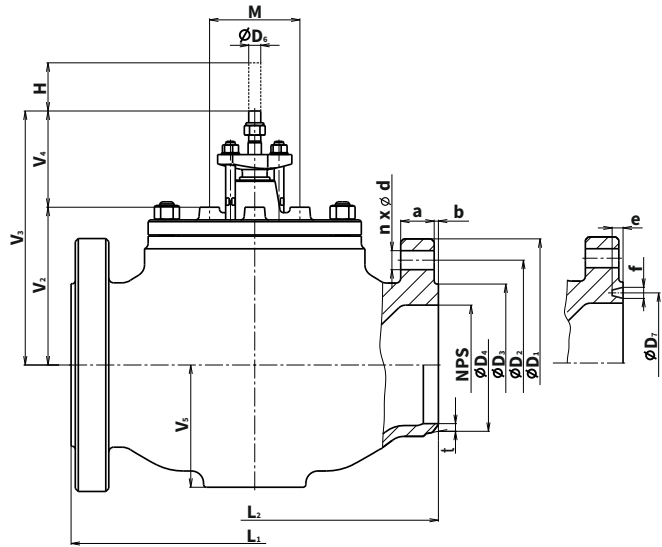

NPS 8" - 16"

NPS	Dimensions of weld ends for pipes ASME B36.10M						
	$\varnothing D_4$	$\varnothing D$	Sch. No. 40	Sch. No. 80	Sch. No. 100	$\varnothing D_{4,max}$	$\varnothing D_{4,min}$
1/2"	22	21.3	2.8	3.9	---	30	13
	0.866	0.839	0.109	0.154	---	1.181	0.512
1"	35	33.4	3.4	4.6	---	40	23
	1.378	1.315	0.133	0.179	---	1.575	0.906
1 1/2"	50	48.3	3.7	5.1	---	57	35
	1.969	1.66	0.14	0.191	---	2.244	1.378
2"	62	60.3	3.9	5.5	---	67	43
	2.44	2.375	0.154	0.218	---	2.638	1.693
3"	91	88.9	5.5	7.6	---	100	72
	3.583	3.5	0.216	0.3	---	3.937	2.835
4"	117	114.3	6.0	8.6	---	128	92
	4.606	4.5	0.237	0.337	---	5.039	3.622
6"	172	168.3	7.1	11.0	---	188	136
	6.772	6.625	0.28	0.432	---	7.402	5.354
8"	223	219.1	8.2	12.7	15.1	228	178
	8.78	8.625	0.322	0.5	0.594	8.976	7.008
10"	278	273.0	9.3	15.1	18.3	278	229
	10.945	10.748	0.366	0.594	0.72	10.945	9.016
12"	329	323.9	10.3	17.5	21.4	329	281
	12.953	12.752	0.406	0.689	0.843	12.953	11.063
16"	413	406.4	12.7	21.4	26.2	426	345
	16.26	16.0	0.5	0.843	1.031	16.772	13.583

t-wall thickness of weld ends: $t = [D_4 - (D - 2 * t_r)] / 2$

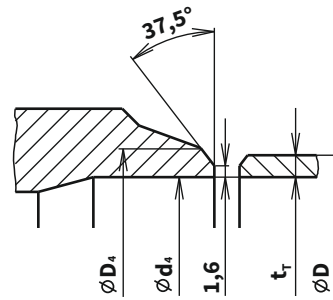

NPS	Dimensions of weld ends for pipes ASME B16.11									
	SW Class 150 and 300					SW Class 600				
	$\varnothing D_5$	$\varnothing D_6$	$\varnothing D_7$	L_3	h	$\varnothing D_5$	$\varnothing D_6$	$\varnothing D_7$	L_3	h
1/2"	15	22	33	206	9.5	12	22	35	206	9.5
	0.59	0.87	1.3	8.11	0.37	0.47	0.87	1.38	8.11	0.37
1"	26	34.1	47	210	12.5	21	34.1	51	210	12.5
	1.02	1.34	1.85	8.27	0.49	0.83	1.34	2.01	8.27	0.49
1 1/2"	41	49	62	251	12.5	34	49	67	251	12.5
	1.61	1.93	2.44	9.88	0.49	1.34	1.93	2.64	9.88	0.49
2"	52	61.4	76	286	16	43	61.4	84	286	16
	2.05	2.42	2.99	11.26	0.63	1.69	2.42	3.31	11.26	0.63

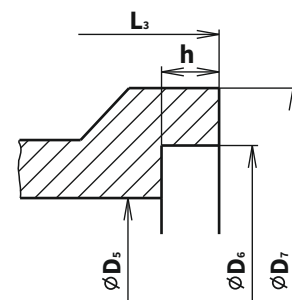



CV 3x2 SP

Pressure balanced
control and shut-off
valves in seismic version

**NPS 1/2" - 16",
Class 150, 300 and 600**

Technical data

Series	CV 322 (Ex)	CV 332 (Ex)
Type of valve	Two-way, single-seated, control (shut-off) valve with pressure balanced plug	
Nominal size range	NPS 1" - 16"	
Nominal pressure	Class 300 and 600 (Class 150, 300 and 600 (weld ended))	
Body material	Cast steel A216 WCB, A217 WC6	Stainless steel A351 CF8M
Seat material:	NPS 1/2" - 2" 1.4028	1.4571
DIN W.Nr./+ČSN	NPS 3" - 16" 1.4027	1.4581
Plug material:	NPS 1/2" - 2" 1.4021	1.4571
DIN W.Nr./+ČSN	NPS 3" - 16" 1.4027	1.4581
Stem material	1.4923	1.4980
Operating temperature range	-50 to 550 °C (-58 to 1020 °F) - (the negative temperature requirement must be specified in the order)	
Face to face dimensions	Acc. to ISA-75.08.01-2002 (R2007) for version with flanges Acc. to ISA-75.08.03-2001 (R2007) for weld ends - version Socket Weld Acc. to ISA - 75.08.05-2002 (R2007) for weld ends - version Butt Weld	
Connection flanges	Acc. to ASME B16.5-2013	
Flange faces	RF (Raised Face), RTJ (Ring Joint Face), LFF (Large Female Face), SFF (Small Female Face), LGF (Large Groove Face), SGF (Small Groove Face)	
Weld ends	Butt Weld 1/2" - 16" acc. to ASME B16.25-2012; Socket Weld 1/2" - 2" acc. to ASME B16.11-2011	
Type of plug	V-ported, contoured, perforated	
Flow characteristic	Linear, equal-percentage, LDMspline®, parabolic	
Kvs value	1,6 to 1600 m ³ /h (1,85 to 1850 US gallon/min)	
Leakage rate	Class III. acc. to ANSI/FCI 70-2-2013 (<0,1% Cv) for control valves with metal-metal seat sealing Class IV. acc. to ANSI/FCI 70-2-2013 (<0.01% Cv) for control valves with metal-PTFE sealing	
Leakage rate for Ex version	Class IV. acc. to ANSI/FCI 70-2-2013 (<0.01% Cv)	
Rangeability r	50 : 1	
Packing	DRSpack® (PTFE) t _{max} = 260 °C (500°F), Expanded graphite t _{max} = 550 °C (1020°F), Bellows (DN15-150) t _{max} = 550°C (1020°F)	
Seismic resistance	0 to 33 Hz, 30 m.s ⁻²	

Cv (Kvs) values and differential pressures Δp_{max} [MPa], [psi] of pressure balanced valves NPS 1" - 16" with electro-mechanic actuators

Δp_{max} value is the valve max. differential pressure when max open - close function is always guaranteed.

Differential pressure must not exceed 2,0 MPa (290 psi) for valves Class 150 and 5,0 MPa (750 psi) for valves Class 300. In regard of service life of seat and plug, it is recommended so that permanent differential pressure would not exceed 1.6 MPa / 232 psi. Otherwise it is suitable to use perforated plug (Δp up to 4,0 MPa / 580 psi) or sealing surfaces of seat and plug with a hard metal overlay (Δp up to 2,5 MPa / 363 psi).

For further information on actuating, see actuators' catalogue sheets			Actuating (actuating)					Auma		Auma		Auma		Hand wheel	
			Marking in valve spec. No.					EA...		EA...		EA...		Rxx	
			Linear force					5 kN		15 kN		20 kN			
*) max. NPS 12"			Kvs [m ³ /h] Cv [US galon/min]					Δp_{max} [MPa] [psi]		Δp_{max} [MPa] [psi]		Δp_{max} [MPa] [psi]		Δp_{max} [MPa] [psi]	
NPS	H[mm]	Ds[mm]	1	2	3	4	5	graphite	PTFE	graphite	PTFE	graphite	PTFE	graphite	PTFE
1"	16	25	10	6.3 ⁵⁾	4.0 ⁵⁾	2.5 ⁵⁾	1.6 ⁵⁾	10	10	---	---	---	---	10	10
			11.6	7.28⁵⁾	4.62⁵⁾	2.89⁵⁾	1.85⁵⁾	1450	1450					1450	1450
1½"	16	40	25	16	10	6.3 ⁵⁾	4.0 ⁵⁾	10	10	---	---	---	---	10	10
			28.9	18.5	11.6	7.28⁵⁾	4.62⁵⁾	1450	1450					1450	1450
2"	20	50	40	25	16	10	6.3 ⁵⁾	10	10	---	---	---	---	10	10
			46.2	28.9	18.5	11.6	7.28⁵⁾	1450	1450					1450	1450
3"	40	80	100	63	40	25	16	10	10	---	---	---	---	10	10
			116	72.8	46.2	28.9	18.5	1450	1450					1450	1450
4"	40	100	160	100	63	40	25	10	10	---	---	---	---	10	10
			185	116	72.8	46.2	28.9	1450	1450					1450	1450
6"	150	360	250	160	100	63	10	10	10	10	---	---	10	10	
			416	289	185	116	72.8	1450	1450	1450	1450			1450	1450
8"	80	200	570	400	250	160	100	---	---	10	10	10	10	10	10
			659	462	289	185	116			1450	1450	1450	1450	1450	1450
10"	80	230	800	630	400	250	160	---	---	---	---	10	10	10	10
			925	728	462	289	185					1450	1450	1450	1450
12"	250	1000	800	630	400	250	---	---	---	---	10	10	10	10	
			1160	925	728	462	289					1450	1450	1450	1450
16"	100	330	1600	1000	630	400	250	---	---	---	---	10	10	10	10
			1850	1160	728	462	289					1450	1450	1450	1450

⁵⁾ linear characteristic only

Max. differential pressures specified in table apply to PTFE and graphite packing.

Perforated plug available only with Cv (Kvs) values in shadowed frames with the following restrictions:

- perforated plug with Kvs value acc. to column No. 2 available with linear or parabolic characteristic only

Dimensions and weights of valves CV 320 SP (Ex) and CV 330 SP (Ex) with flanges and weld ends, NPS 1" - 16"

NPS	H	V ₂	V ₃	V ₄	ØD ₅	M	ØD ₆	V ₅	m ₁	m ₂	Class 300			Class 600			Class 150 - 600				
											L ₁			L ₁			L ₂				
											RF	RTJ	LFF SFF LGF SGF	RF	RTJ	LFF SFF LGF SGF	BTW				
[mm] [inch]	[mm] [inch]	[mm] [inch]	[mm] [inch]	[mm] [inch]	[mm] [inch]	[mm] [inch]	[mm] [inch]	kg kg	[mm] [inch]	[mm] [inch]	[mm] [inch]	[mm] [inch]	[mm] [inch]	[mm] [inch]							
1"	16	73	162	89	65	---	M10x1	52	9.5	6.5	197	210	207	210	210	207	210				
1½"	0.63	2.874	6.378	3.504				52	2.047	9.5	6.5	7.75	8.25	8.15	8.25	8.25	8.15	8.25			
2"	20	104	193	106				73	2.874	21	14	10.5	11.14	10.9	11.25	11.38	11.14	11.25			
3"	139	245	106					105	4.133	43	30	318	332	328	337	340	334	337			
4"	40	139	245					106	105	4.133	69	39	14.5	15.12	14.88	15.5	15.63	15.39	15.5		
6"	179	281	102	160				---	150	M16x1,5	134	163	108	473	489	483	508	511	505	508	
8"	80(63 ¹⁾ 3.15 (2.48) ¹⁾	262	422		106	203	7.992				292	212	22.38	22.99	22.75	24.0	24.13	60.72	24.0		
10"	80	346	506		106	253	9.961				555	385	27.88	28.5	28.27	29.62	29.72	29.49	29.62		
12"	80	395	555		6.299	296	11.654				706	546	30.5	31.14	30.91	32.25	32.36	32.13	32.25		
16"	100	512	672		---	---	5.905				M20x1,5	382	1423	1173	1057	1073	1067	1108	1111	1105	1108
	3.937	20.157	26.457									203	7.992	292	212	22.38	22.99	22.75	24.0	24.13	60.72
				253				9.961	555	385		27.88	28.5	28.27	29.62	29.72	29.49	29.62			
				296				11.654	706	546		30.5	31.14	30.91	32.25	32.36	32.13	32.25			
				382				15.039	1423	1173		41.62	42.24	42.01	43.62	43.74	43.5	43.62			

1) NPS 8" balanced by graphite - travel = 63 mm (2,48 inch)

NPS	RF Class 300							RF Class 600							RTJ Class 300 a 600					
	ØD ₁	ØD ₂	ØD ₃	d	n	a	b	ØD ₁	ØD ₂	ØD ₃	d	n	a	b	ØD ₇	e	f	Groove Number		
	[mm] [inch]	[mm] [inch]	[mm] [inch]	[mm] [inch]	[mm] [inch]	[mm] [inch]	[mm] [inch]	[mm] [inch]	[mm] [inch]	[mm] [inch]	[mm] [inch]	[mm] [inch]	[mm] [inch]	[mm] [inch]	[mm] [inch]	[mm] [inch]				
1"	125	88.9	50.8	19.1	4	15.9	0.06	125	88.9	50.8	19.1	4	17.5	7	50.8	6.35	8.74		R16	
1½"	155	114.3	73	22.3	4	19.1		155	114.3	73	22.3	4	22.3		68.27	6.35	8.74	R20		
2"	165	127	92.1	19.1	8	20.7		165	127	92.1	19.1	8	25.4		82.55	7.92	11.91	R23		
3"	210	168.3	127	22.3	8	27		210	168.3	127	22.3	8	31.8		117.48	7.92	11.91	R30		
4"	255	200	157.2	22.3	12	30.2		275	215.9	157.2	25.4	12	38.1		149.23	7.92	11.91	R37		
6"	320	269.9	215.9	22.3	12	35		355	292.1	215.9	28.6	12	47.7		211.12	7.92	11.91	R45		
8"	380	330.2	269.9	25.4	12	39.7		420	349.2	269.9	31.8	12	55.6		269.9	7.92	11.91	R49		
10"	445	387.4	323.8	28.6	16	46.1		510	431.8	323.8	34.9	16	63.5		323.85	7.92	11.91	R53		
12"	520	450.8	381	31.8	16	49.3		560	489	381	34.9	20	66.7		381	7.92	11.91	R57		
16"	650	571.5	469.9	34.9	20	55.6		685	603.2	469.9	41.3	20	76.2		469.9	7.92	11.91	R65		

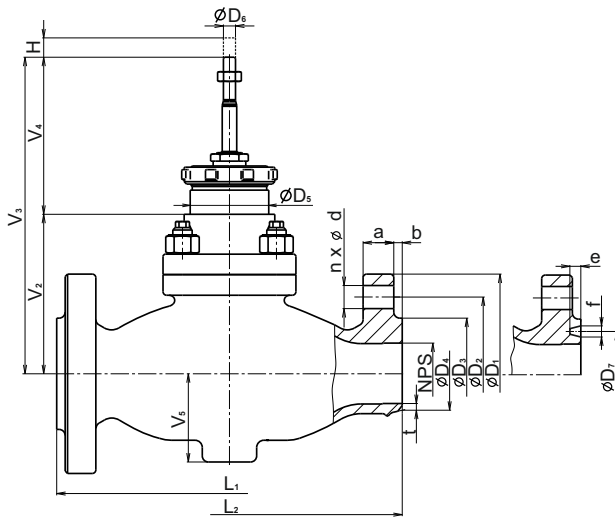

NPS 1" - 6"

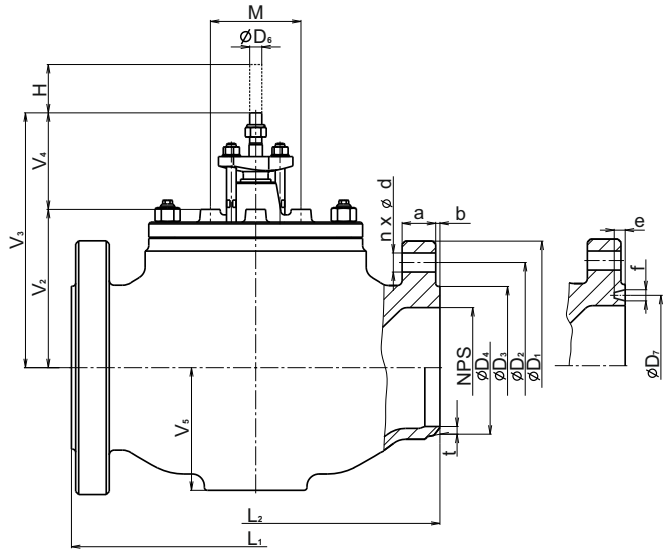

NPS 8" - 16"

NPS	Dimensions of weld ends for pipes ASME B36.10M					[mm] [inch]	
	$\varnothing D_4$	$\varnothing D$	Sch. No. 40	Sch. No. 80	Sch. No. 100	$\varnothing D_{4max}$	$\varnothing D_{4min}$
1"	35 1.378	33.4 1.315	3.4 0.133	4.6 0.179	---	40 1.575	23 0.906
1½"	50 1.969	48.3 1.66	3.7 0.14	5.1 0.191	---	57 2.244	35 1.378
2"	62 2.44	60.3 2.375	3.9 0.154	5.5 0.218	---	67 2.638	43 1.693
3"	91 3.583	88.9 3.5	5.5 0.216	7.6 0.3	---	100 3.937	72 2.835
4"	117 4.606	114.3 4.5	6.0 0,237	8.6 0.337	---	128 5.039	92 3.622
6"	172 6.772	168.3 6.625	7.1 0,28	11.0 0.432	---	188 7.402	136 5.354
8"	223 8.78	219.1 8.625	8.2 0.322	12.7 0.5	15.1 0.594	228 8.976	178 7.008
10"	278 10.945	273.0 10.748	9.3 0.366	15.1 0.594	18.3 0.72	278 10.945	229 9.016
12"	329 12.953	323.9 12.752	10.3 0.406	17.5 0.689	21.4 0.843	329 12.953	281 11.063
16"	413 16.26	406.4 16.0	12.7 0.5	21.4 0.843	26.2 1.031	426 16.772	345 13.583

t-wall thickness of weld ends: $t = [D_4 - (D - 2 * t_r)] / 2$

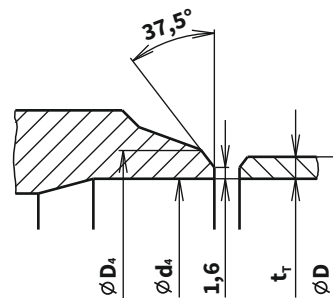

NPS	Dimensions of weld ends for pipes ASME B16.11					[mm] [inch]				
	$\varnothing D_5$	$\varnothing D_6$	$\varnothing D_7$	L_3	h	$\varnothing D_5$	$\varnothing D_6$	$\varnothing D_7$	L_3	h
1"	26 1.02	34,1 1.34	47 1.85	210 8.27	12.5 0.49	21 0.83	34.1 1.34	51 2.01	210 8.27	12.5 0.49
1½"	41 1.61	49 1.93	62 2.44	251 9.88	12.5 0.49	34 1.34	49 1.93	67 2.64	251 9.88	12.5 0.49
2"	52 2.05	61,4 2.42	76 2.99	286 11.26	16 0.63	43 1.69	61.4 2.42	84 3.31	286 11.26	16 0.63

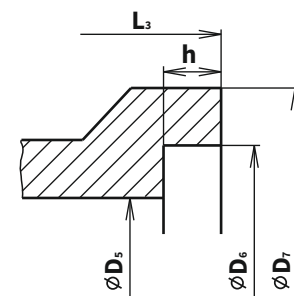

Valve complete specification No. for ordering CV/SV3x0 SP (Ex), CV3x2 SP (Ex)

		XX	XXX	XXX	XXXX	XX	XXX	/XXX	-XXX	XXXX
1. Valve	Control valve	CV								
	Shut-Off valve	SV								
2. Series	Valves made of steel		3 2							
	Valves made of stainless steel		3 3							
	Straight-through		0							
	Straight-through with pressure balanced plug		2							
3. Actuating *)	Electric actuator			E X X						
	Hand wheel			R X X						
4. Connection	Flange RF (Raised Face)									1
	Flange RTJ (Ring Joint Face)									2
	Flange LFF (Large Female Face)									3
	Flange SFF (Small Female Face)									4
	Flange LGF (Large Groove Face)									5
	Flange SGF (Small Groove Face)									6
	Weld ends BW (Butt Welding)									7
	Weld ends SW (Socket Welding)									8
5. Body material	Cast steel A216 WCB (-29 to 425°C); (-20 to 800°F) ⁵⁾									1
	CrMo steel A217 WC6 (-29 to 550°C); (-20 to 1020°F) ⁵⁾									7
	Stainless steel A351 CF8M (-50 to 550°C); (-58 to 1020°F) ⁵⁾									8
	Other material on request									9
6. Seat sealing	Metal - metal									1
	Soft sealing (metal - PTFE) ²⁾									2
	Hard metal overlay on sealing surfaces									3
	Balanced by graphite, metal-metal ³⁾									5
	Balanced by graphite, hard metal overlay ⁴⁾									7
7. Packing	DRSpack® (PTFE)									3
	Expanded graphite									5
	Bellows ¹⁾									7
	Bellows with safety packing PTFE ¹⁾									8
	Bellows with safety packing Graphite ¹⁾									9
8. Flow characteristic	Linear									L
	Equal-percentage									R
	LDMspline®									S
	On-off									U
	Parabolic									P
	Linear - perforated plug									D
	Equal-percentage - perforated plug									Q
Parabolic - perforated plug									Z	
9. Cvs	Column no. acc. to Kvs (Cv) value table									X
10. Nominal pressure	Class 150 (weld ends only)									150
	Class 300									300
	Class 600									600
11. Max. operating temperature °C (°F)	Acc. to version 260 - 550°C (500 - 1020°F)							XXX		
12. Nominal size	DN (NPS)								XXX	
13. Execution	Seismically resistant									SP
	Seismically resistant, non-explosive									SPEX

DN	NPS	DN	NPS	Temp.	
				°C	°F
015	1/2"	065	2 1/2"	260	500
020	3/4"	080	3"	300	570
025	1"	100	4"	315	600
032	1 1/4"	125	5"	400	750
040	1 1/2"	150	6"	425	800
050	2"	200	8"	500	930
		250	10"	550	1020

Ordering example of flanged execution:
CV320 ENC 2135 L1 300/400-080

Ordering example of weld ends execution:
**CV320 ENC 7135 L1 300/400-080,
weld ends size Ø 88,9 x 5,5**

*) For marking of actuators in specification code, refer to table on page No. 24 of this catalogue

Valves CV / SV 3x0 SP (Ex)

Section of valve with V-ported plug

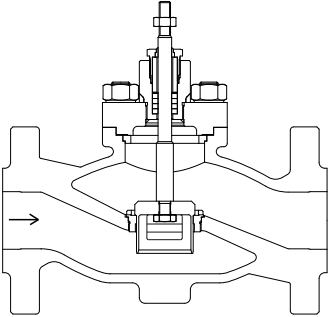

Section of valve with perforated plug

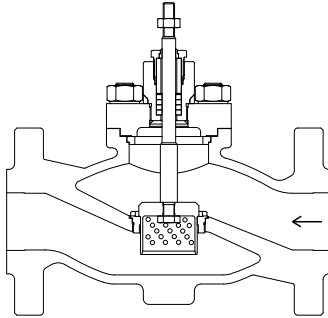

Section of valve with micro-throttling system

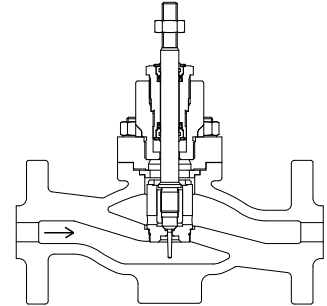

Valves CV 3x2 SP (Ex)

Section of pressure-balanced valve with V-ported plug

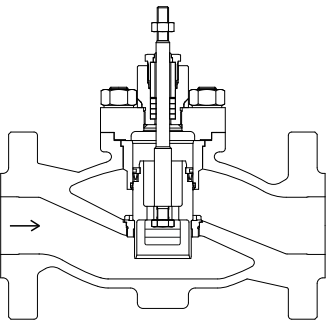

Section of pressure-balanced valve with perforated plug

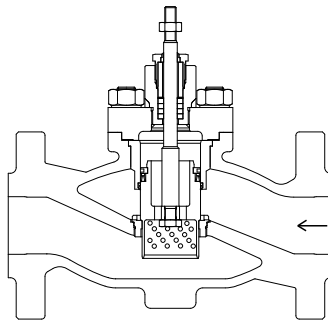



Electric actuators

Auma

**SA 07.2, SA Ex 07.2,
SAR 07.2, SAR Ex 07.2,
SA 07.6, SA Ex 07.6,
SAR 07.6, SAR Ex 07.6**

marking in type number:

**EAA, EAB, EAC, EAD
EAE, EAF, EAG, EAH**

Technical data								
Type	SA 07.2	SA Ex 07.2	SAR 07.2	SAR Ex 07.2	SA 07.6	SA Ex 07.6	SAR 07.6	SAR Ex 07.6
Marking in valve spec. No.	EAA	EAB	EAC	EAD	EAE	EAF	EAG	EAH
Voltage	3-phase ~ 380 or 400 V AC (1-phase ~ 230 V AC cannot be used - high weight)							
Frequency	50 Hz							
Power consumption	see specification table							
Control	3 - position control or with signal 4 - 20 mA							
Nominal force	10 Nm~5 kN; 15 Nm~7,5 kN; 20 Nm~10 kN				30 Nm~15 kN; 40 Nm~20 kN			
Travel	acc. to used valve 16, 25, 40 mm				acc. to used valve 40, 80 mm			
Enclosure	IP 68							
Process medium max. temp.	acc. to used valve							
Ambient temperature range	-40 to 80°C	-20 to 60°C	-40 to 60°C	-20 to 60°C	-40 to 80°C	-20 to 60°C	-40 to 60°C	-20 to 60°C
Ambient humidity range	100 %							
Weight								
- single-phase	25 - 62 kg				25 - 62kg			
- three-phase	20 - 33 kg				21 - 33 kg			

→ **Note:** Specifications and technical data are for information only.

Detailed technical informations can be found in producer's data sheet or on the webside www.auma.com

Specification of Auma actuators					SA	X	XX	07.X
Type					SA			
Duty					SA	R		
Version							Ex	
Actuator size								07.2 07.6
Output shaft type A (thread TR 16x4 LH, connection flange F07) ... for CV 3xx NPS ½" - 6"								
Output speed [ot/min]	Tripping torque	SA 07.2	SAR 07.2	Motor power [kW]	SA 07.2	SA Ex 07.2	SAR 07.2	SAR Ex 07.2
		SA Ex 07.2	SAREx 07.2		S2-15min	S2-15min	S4-25%	S4-25%
4		10-30 Nm	15-30 Nm		0,02	0,02	0,02	0,02
5,6				0,02	0,02	0,02	0,02	
8				0,04	0,04	0,04	0,04	
11				0,04	0,04	0,04	0,04	
16				0,06	0,06	0,06	0,06	
22				0,06	0,06	0,06	0,06	
32				0,10	0,10	0,10	0,10	
45				0,10	0,10	0,10	0,10	
Output shaft type A (thread TR 20x4 LH, flange F10) ... for CV 3xx DN 3" - 16"								
Output speed [ot/min]	Tripping torque	SA 07.6	SAR 07.6	Motor power [kW]	SA 07.6	SA Ex 07.6	SAR 07.6	SAR Ex 07.6
		SA Ex 07.6	SAREx 07.6		S2-15min	S2-15min	S4-25%	S4-25%
4		20-60 Nm	30-60 Nm		0,03	0,03	0,03	0,03
5,6				0,03	0,03	0,03	0,03	
8				0,06	0,06	0,06	0,06	
11				0,06	0,06	0,06	0,06	
16				0,12	0,12	0,12	0,12	
22				0,12	0,12	0,12	0,12	
32				0,20	0,20	0,20	0,20	
45				0,20	0,20	0,20	0,20	

Accessories

- 2 TANDEM switches
- Gearing for signalisation of position
- Mechanical position indicator
- Potentiometer 1x200 Ω
- Electronic position transmitter RWG (potentiometer included), 4 - 20 mA, 2-wire
- Electronic position transmitter RWG (potentiometer included), 4 - 20 mA, 3/4-wire
- Inductive position transmitter IWG, 4 - 20 mA
- MATIC - or continuous control (specification of accessories acc. to catalogue of producer: IP 67; -25 to +70°C; ...), weight + 7 kg
- AUMATIC - or continuous control (specification of accessories acc. to catalogue of producer: IP 68; -25 to +70°C; ...), weight + 7kg

Other accessories acc. to catalogue of producer of actuators.

Dimensions of actuators Auma series 07.2 and 07.6

Normal version

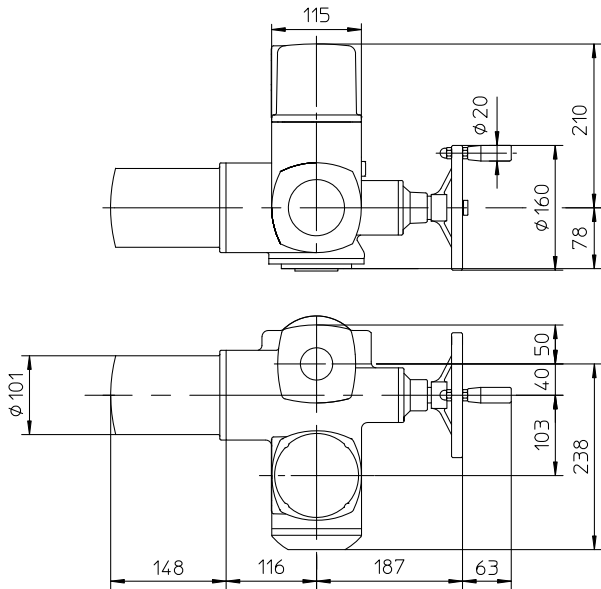

Version Ex norm

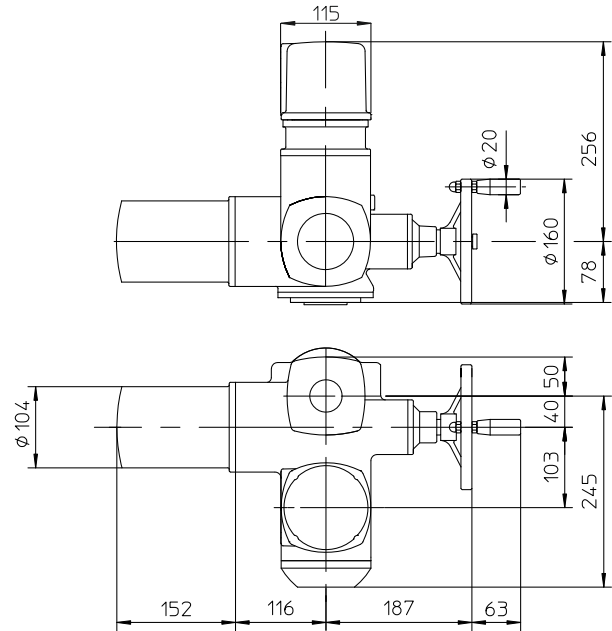

Version MATIC

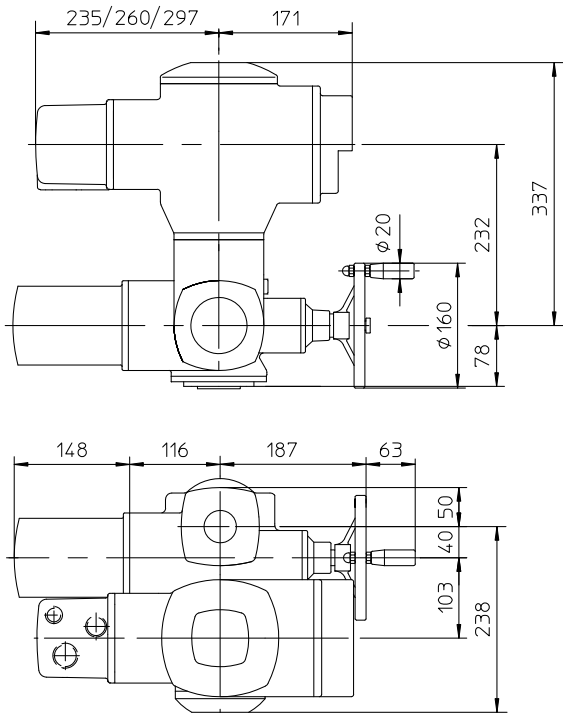

Version Ex MATIC

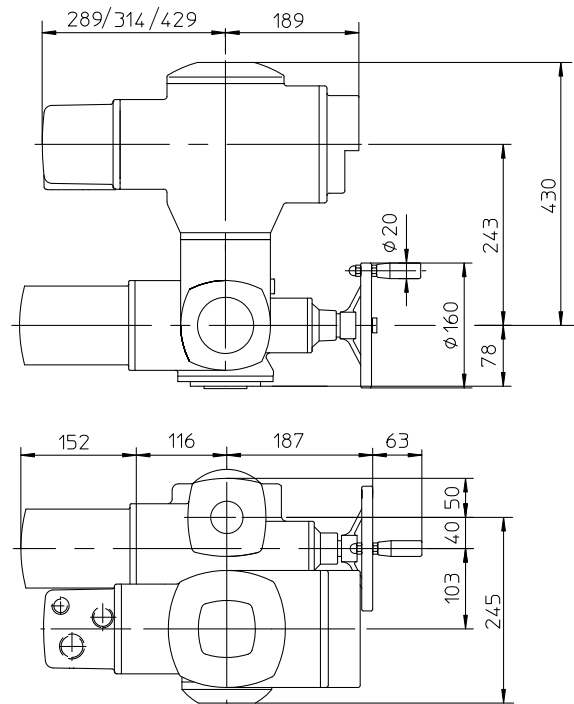

Version with AUMATIC

Version Ex AUMATIC

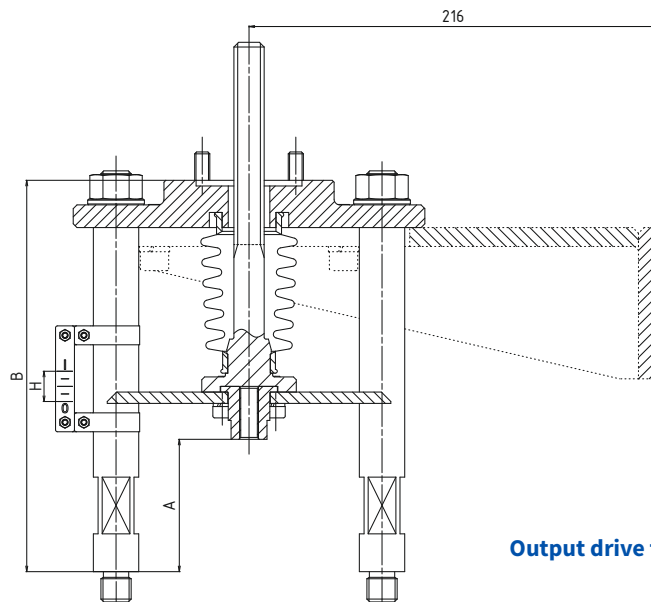
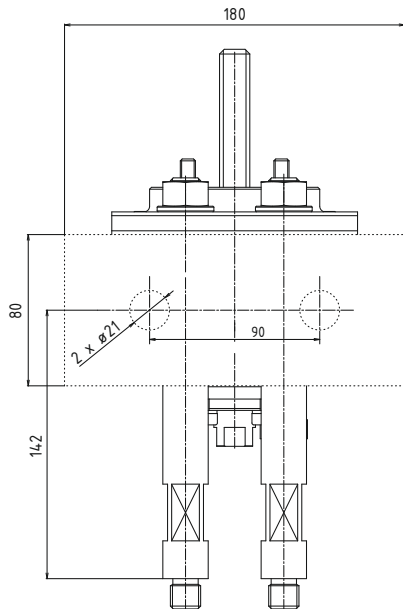
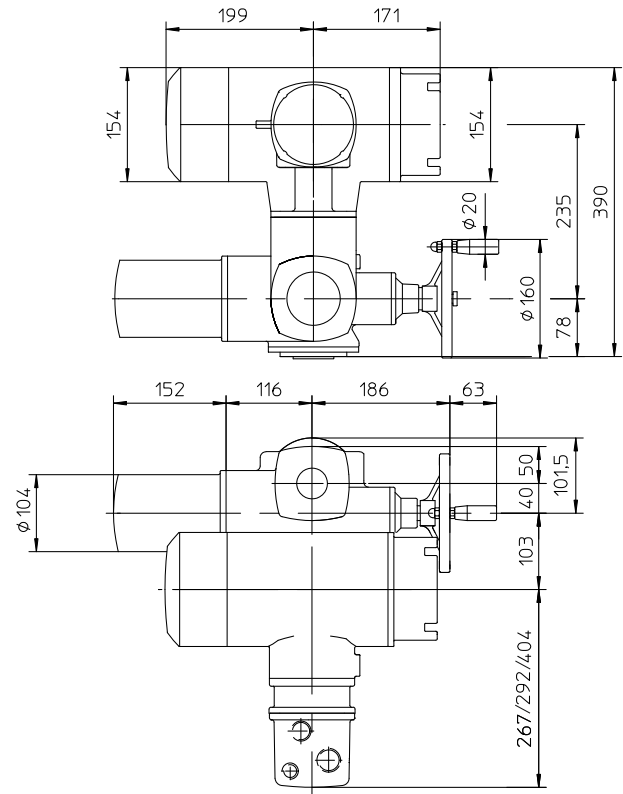
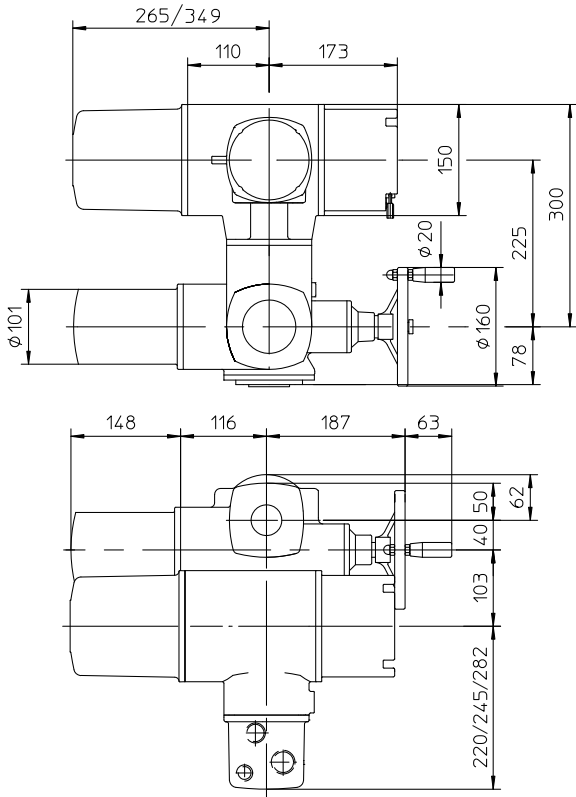

Output drive type A, F07

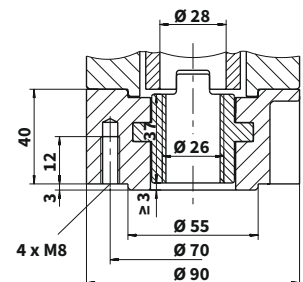

For valves	Number of columns	A	B	Weight [kg]
CV 3xx NPS 1/2"- 2"	4	149	295	6 kg (+ 6 kg console)
CV 3xx NPS 3"- 6"	4	141	295	8 kg
CV 3xx NPS 8"- 16"	4	141	323	15 kg

console required for NPS 1/2"- 1" - all versions AUMA SAR 07.2 max. 33kg (Norm, Matic, Aumatic, Ex), with exception NPS 1" AUMA SAR 07.2 Norm max. 24,3kg



Electric actuators

Auma

SA 10.2, SA Ex 10.2
SAR 10.2, SAR Ex 10.2

marking in type number:

EAI, EAJ, EAK, EAL

Technical data				
Type	SA 10.2	SA Ex 10.2	SAR 10.2	SAR Ex 10.2
Marking in valve spec. No.	EAI	EAL	EAJ	EAK
Voltage	3-phase ~ 380 or 400 V AC (1-phase ~ 230 V AC not applicable - high weight)			
Frequency	50 Hz			
Power consumption	see specification table			
Control	3 - point or with signal 4 - 20 mA			
Nominal force	80 Nm ~ 21,6 kN; 100 Nm ~ 27 kN; 120 Nm ~ 32 kN			
Travel	80, 100 mm			
Enclosure	IP 68			
Process medium max. temp.	acc. to used valve			
Ambient temperature range	-40 to 80 °C	-20 to 60 °C	-40 to 60 °C	-20 to 60 °C
Ambient humidity range	100 %			
Weight	22 to 47 kg			
Vibration resistance acc. to EN 60068-2-6	AUMA NORM: 2g, 10-200Hz; AUMA MATIC: 1g, 10-200Hz; AUMATIC: 1g, 10-200Hz			

→ **Note:** Specifications and technical data are for information only.

Detailed technical informations can be found in producer's data sheet or on the website www.auma.com

Specification of Auma actuators

		SA	X	XX	10.2		
Type		SA					
Duty	control ON - OFF		R				
Version	standard non-explosive			Ex			
Actuator size					10.2		
Output drive shaft type A (thread TR 36x6 LH, flange F10) ... for CV 3xx NPS 8" - 16"							
Output speed [ot/min]	Tripping torque	SA 10.2	SAR 10.2	SA 10.2	SA Ex 10.2	SAR 10.2	SAR Ex 10.2
		SA Ex 10.2	SAR Ex 10.2	S2-15min	S2-15min	S4-25%	S4-25%
4	40-120 Nm 60-120 Nm			0,06	0,09	0,09	0,09
5,6				0,06	0,09	0,09	0,09
8				0,12	0,18	0,18	0,18
11				0,12	0,18	0,18	0,18
16				0,25	0,37	0,37	0,37
22				0,25	0,37	0,37	0,37
32				0,40	0,75	0,75	0,75
45				0,40	0,75	0,75	0,75

Accessories

- 2 TANDEM switches
 - Gearing for signalisation of position
 - Mechanical position indicator
 - Potentiometer 1x200 Ω
 - MATIC - or continuous control (specification of accessories acc. to catalogue of producer: IP 67; -25 to +70°C; ...), weight + 7 kg
 - AUMATIC - or continuous control (specification of accessories acc. to catalogue of producer: IP 68; -25 to +70°C; ...), weight + 7kg
- Other accessories acc. to catalogue of producer of actuators.
- Electronic position transmitter RWG (potentiometer included), 4 - 20 mA, 2-wire
 - Electronic position transmitter RWG (potentiometer included), 4 - 20 mA, 3/4-wire
 - Inductive position transmitter IWG, 4 - 20 mA

Dimensions of actuators Auma series 10

Normal version

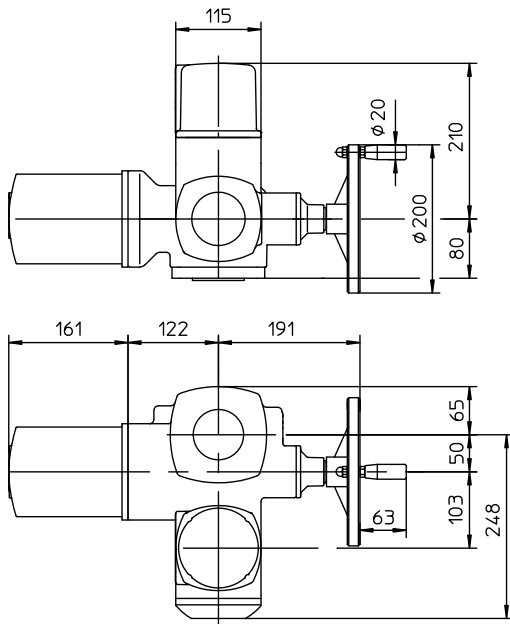

Ex norm version

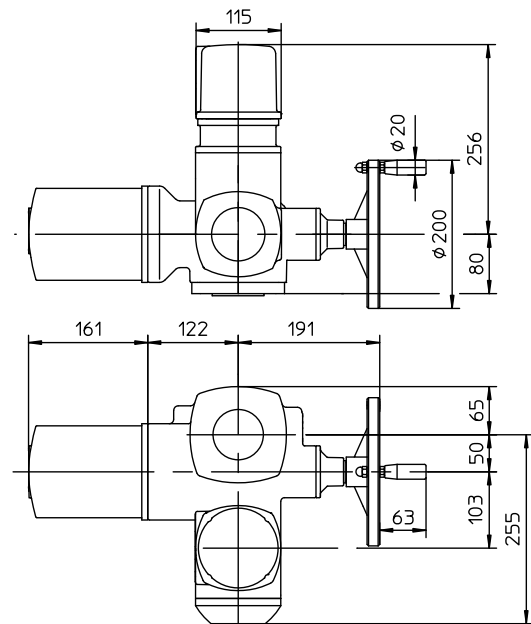

Version with MATIC

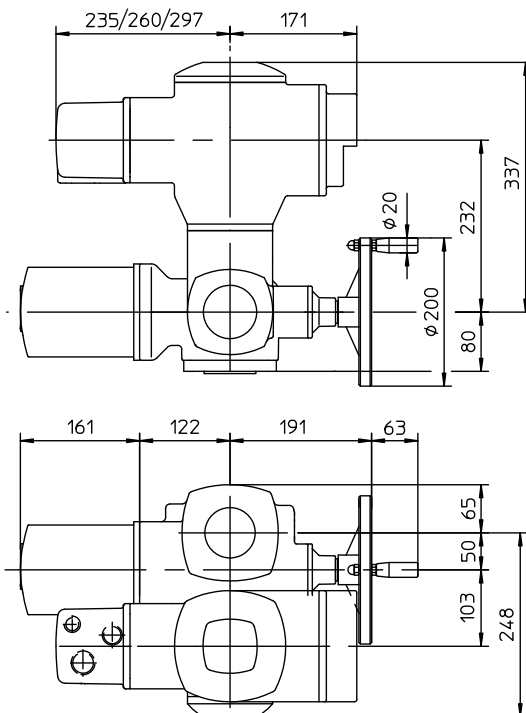

Version with Ex MATIC

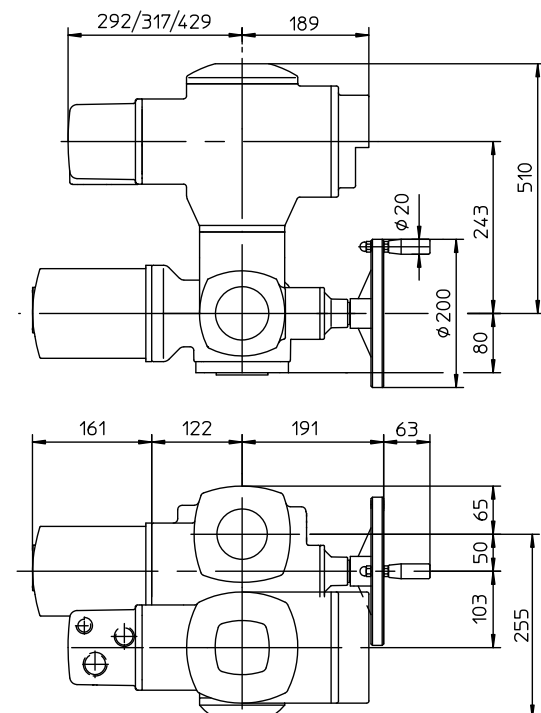

Version AUMATIC

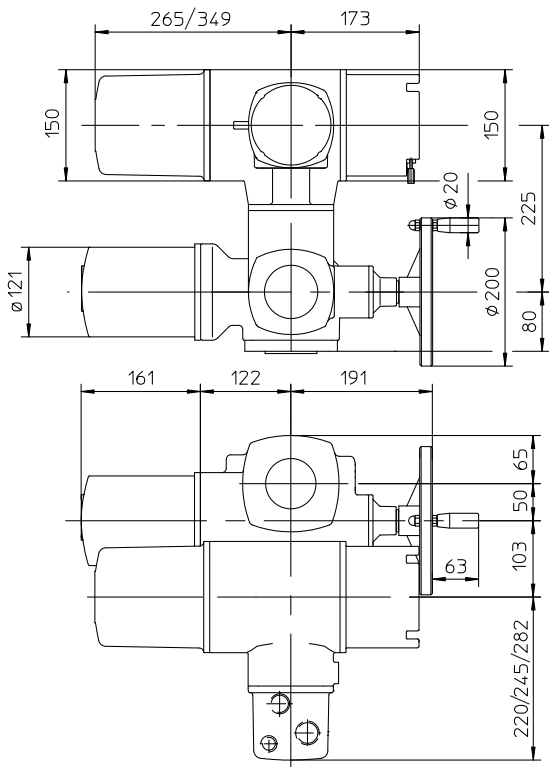

Version Ex AUMATIC

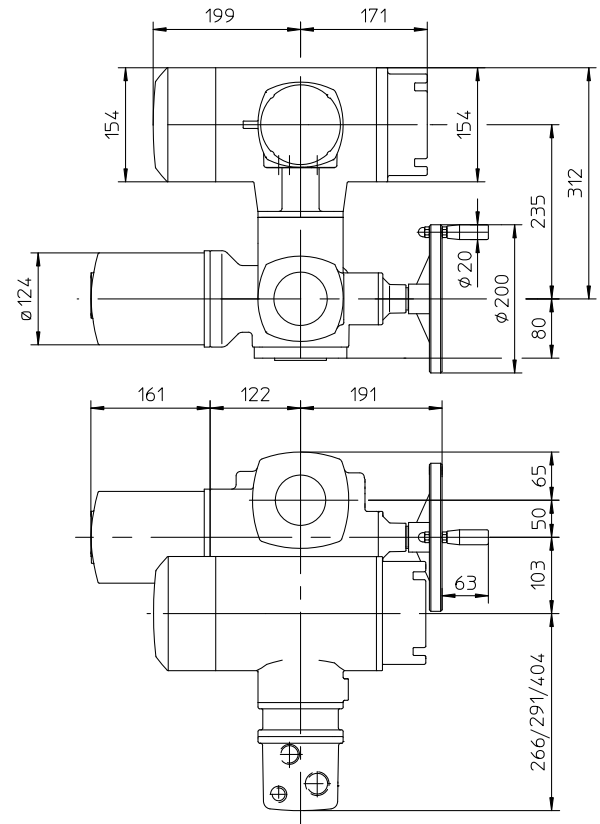

Output drive shaft A, F10

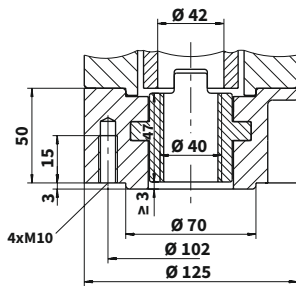

Attachment yoke NPS 8" - 16"
Connection A, F10, Tr36x6-LH

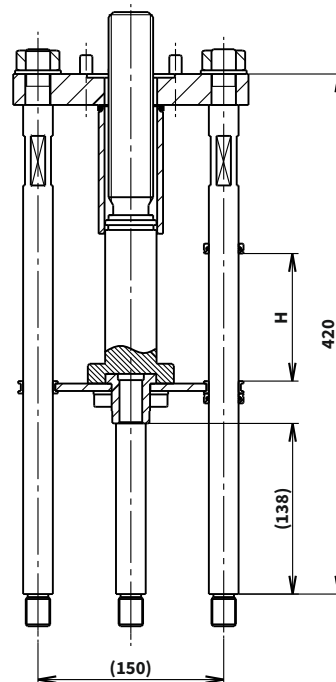

Hand wheels for CV / SV 3x0 SP and CV 3x2 SP

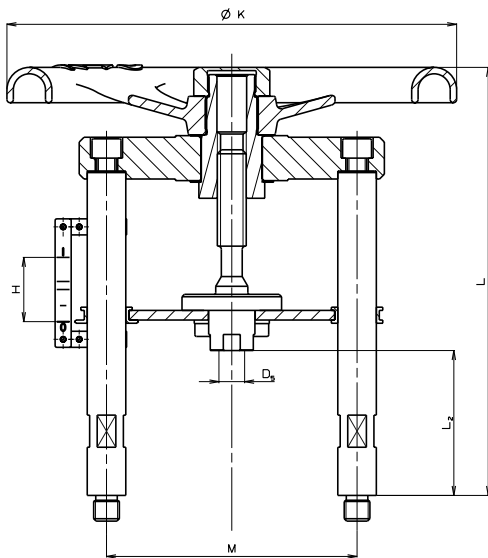

Hand wheel actuating of valves NPS 1/2" - 6"

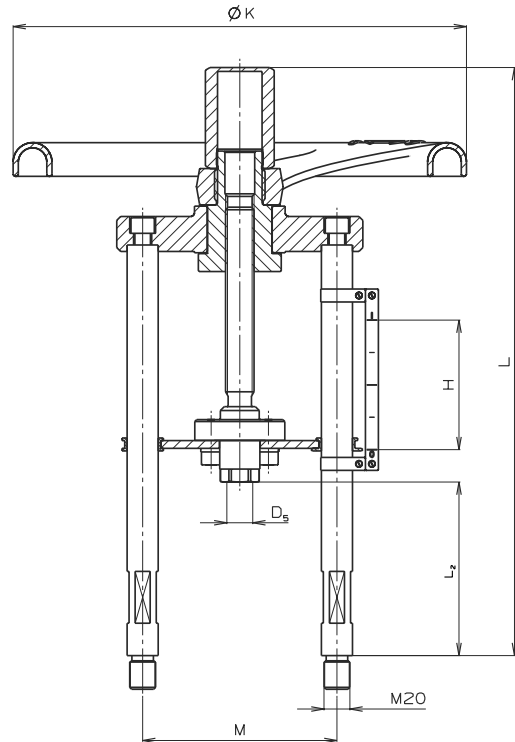

Hand wheel actuating of valves NPS 8" - 16"

Dimensions of hand wheels										
NPS	Marking	H [mm] [inch]	L [mm] [inch]	L ₂ [mm] [inch]	øK [mm] [inch]	M [mm] [inch]	øD _s [mm] [inch]	m kg	Ordering number (part list number)	
1/2"	R16	16	209	70	160	140	M10x1	7	S900 0256	
1"		0,63	8,228		6,299					
1 1/2"		2,756	5,512							
2"	R20	20	235	90	195	156	M16x1,5	12	S900 0257	
3"	R28	40	267		11,024			14,5	S900 0258	
4"		1,575	10,512		3,543			15	S900 0259	
6"		323	12,717	15	S900 0259					
8"	R35	80	454	134	350	150	M20x1,5	15	S900 0141	
10"		3,15	17,874		13,78					5,906
12"		100								
16"		3,94								

Actuator marking in valve specification No.

Electric actuator Auma SA 07.2	EAA	NPS 1/2" - 2"
Electric actuator Auma SA Ex 07.2	EAB	NPS 1/2" - 2"
Electric actuator Auma SAR 07.2	EAC	NPS 1/2" - 2"
Electric actuator Auma SAR Ex 07.2	EAD	NPS 1/2" - 2"
Electric actuator Auma SA 07.6	EAE	NPS 3" - 6"
Electric actuator Auma SA Ex 07.6	EAF	NPS 3" - 6"
Electric actuator Auma SAR 07.6	EAG	NPS 3" - 6"
Electric actuator Auma SAR Ex 07.6	EAH	NPS 3" - 6"
Electric actuator Auma SA 10.2	EAI	NPS 8" - 16"
Electric actuator Auma SAR 10.2	EAJ	NPS 8" - 16"
Electric actuator Auma SAR Ex 10.2	EAK	NPS 8" - 16"
Electric actuator Auma SA Ex 10.2	EAL	NPS 8" - 16"
Hand wheel for NPS 1/2" - 1 1/2"	R16	
Hand wheel for NPS 2"	R20	
Hand wheel for NPS 3" - 4"	R28	
Hand wheel for NPS 6" - 16"	R35	

Maximal permissible operating pressures according to ASME B16.34-2013 [MPa]

Material	Class	Temperature [°C]																
		RT ¹⁾	50	100	150	200	250	300	325	350	375	400	425	450	475	500	538	550
A216 WCB	150	1.96	1.92	1.77	1.58	1.38	1.21	1.02	0.93	0.84	0.74	0.65	0.55	---	---	---	---	---
	300	5.11	5.01	4.66	4.51	4.38	4.19	3.98	3.87	3.76	3.64	3.47	2.88	---	---	---	---	---
	600	10.21	10.02	9.32	9.02	8.76	8.39	7.96	7.74	7.51	7.27	6.94	5.75	---	---	---	---	---
A217 WC 6²⁾	150	1.98	1.95	1.77	1.58	1.38	1.21	1.02	0.93	0.84	0.74	0.65	0.55	0.46	0.37	0.28	0.14	0.14
	300	5.17	5.17	5.15	4.97	4.80	4.63	4.29	4.14	4.03	3.89	3.65	3.52	3.37	3.17	2.57	1.49	1.27
	600	10.34	10.34	10.30	9.95	9.56	9.27	8.57	8.26	8.04	7.76	7.33	7.00	6.77	6.34	5.15	2.98	2.54
A351 CF8M³⁾	150	1.90	1.84	1.62	1.48	1.37	1.21	1.02	0.93	0.84	0.74	0.65	0.55	0.46	0.37	0.28	0.14	0.14
	300	4.96	4.81	4.22	3.85	3.57	3.34	3.16	3.09	3.03	2.99	2.94	2.91	2.88	2.87	2.82	2.52	2.50
	600	9.93	9.62	8.44	7.70	7.13	6.68	6.32	6.18	6.07	5.98	5.89	5.83	5.77	5.73	5.65	5.00	4.98

¹⁾ -29°C to 38°C

²⁾ Normalized annealed material only. The deliberate addition of any element which is not listed in ASTM A 217 is inadmissible, with the exception of Ca and Mg for deoxidation.

³⁾ With a temperature above 540°C (1004°F) use only when the carbon content is $\geq 0,04\%$.

Maximal permissible operating pressures according to ASME B16.34-2013 [psig]

Material	Class	Temperature [°F]														
		RT ¹⁾	200	300	400	500	600	650	700	750	800	850	900	950	1000	1050
A216 WCB	150	285	260	230	200	170	140	125	110	95	80	---	---	---	---	---
	300	740	680	655	635	605	570	550	530	505	410	---	---	---	---	---
	600	1480	1360	1310	1265	1205	1135	1100	1060	1015	825	---	---	---	---	---
A217 WC6²⁾	150	290	260	230	200	170	140	125	110	95	80	65	50	35	20	20
	300	750	750	720	695	665	605	590	570	530	510	485	450	320	215	145
	600	1500	1500	1445	1385	1330	1210	1175	1135	1065	1015	975	900	640	430	290
A351 CF8M³⁾	150	275	235	215	195	170	140	125	110	95	80	65	50	35	20	20
	300	720	620	560	515	480	450	440	435	425	420	420	415	385	365	360
	600	1440	1240	1120	1025	955	900	885	870	855	845	835	830	775	725	720

¹⁾ -20°F to 100°F

²⁾ Normalized annealed material only. The deliberate addition of any element which is not listed in ASTM A 217 is inadmissible, with the exception of Ca and Mg for deoxidation.

³⁾ With a temperature above 540°C (1004°F) use only when the carbon content is $\geq 0,04\%$.



LDM, spol. s r.o.
Litomyšlská 1378
560 02 Česká Třebová
Czech Republic

tel.: +420 465 502 511
fax: +420 465 533 101
e-mail: sale@ldm.cz

LDM, spol. s r.o.
Office Praha
Podolská 50
147 01 Praha 4
Czech Republic

tel.: +420 241 087 360
fax: +420 241 087 192
e-mail: sale@ldm.cz

LDM, spol. s r.o.
Office Ústí nad Labem
Ladova 2548/38
400 11 Ústí nad Labem
- Severní Terasa
Czech Republic

tel.: +420 602 708 257
e-mail: tomas.kriz@ldm.cz

LDM servis, spol. s r.o.
Litomyšlská 1378
560 02 Česká Třebová
Česká Republika

tel.: +420 465 502 411-3
fax: +420 465 531 010
e-mail: servis@ldm.cz

LDM Bratislava s.r.o.
Mierová 151
821 05 Bratislava
Slovakia

tel.: +421 2 43415027-8
fax: +421 2 43415029
e-mail: ldm@ldm.sk

LDM, Polska Sp. z o.o.
ul. Bednorza 1
40 384 Katowice
Poland

tel.: +48 32 730 56 33
fax: +48 32 730 52 33
mobile: +48 601 354 999
e-mail: ldmpolska@ldm.cz

LDM Armaturen GmbH
Wupperweg 21
D-51789 Lindlar
Germany

tel.: +49 2266 440333
fax: +49 2266 440372
mobile: +49 177 2960469
e-mail: ldmmarmaturen@ldmvalves.com

OOO "LDM Promarmatura"
Jubilejnyj prospekt,
dom.6a, of. 601
141400 Khimki Moscow Region
Russia

tel.: +7 4957772238
fax: +7 4956662212
mobile: +7 9032254333
e-mail: inforus@ldmvalves.com

TOO "LDM"
Shakirova 33/1
kab. 103
100012 Karaganda
Kazakhstan

tel.: +7 7212 566 936
fax: +7 7212 566 936
mobile: +7 701 738 36 79
e-mail: sale@ldm.kz

LDM - Bulgaria - OOD
z. k. Mladost 1
bl. 42, floor 12, app. 57
1784 Sofia
Bulgaria

tel.: +359 2 9746311
fax: +359 2 9746311
mobile: +359 888 925 766
e-mail: ldm.bg@ldmvalves.com

www.ldmvalves.com

LDM, reserves the right to modify or improve the designs or specifications of such products at any time without notice

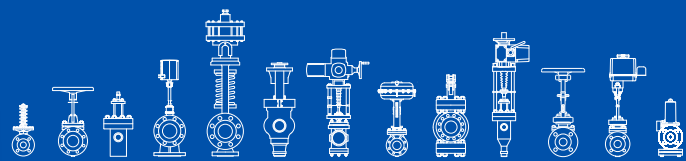
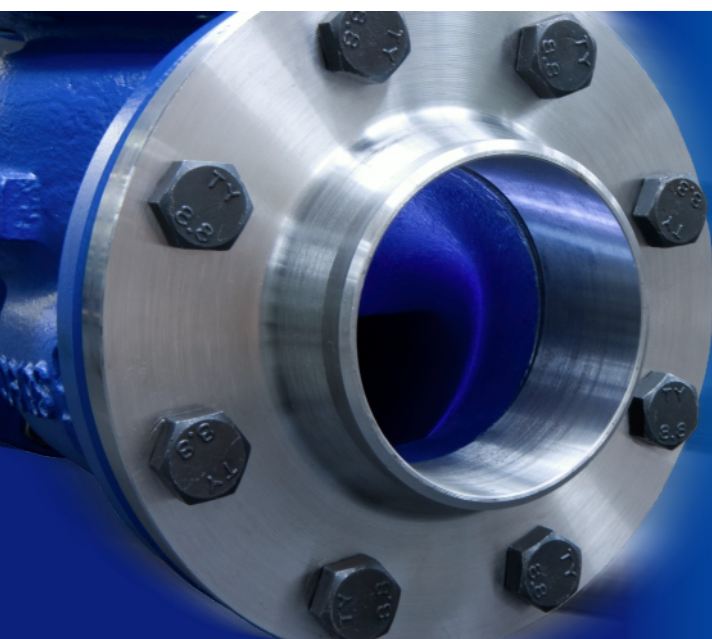

POWER THROUGH IDEAS