



01 - 02.2
04.20.GB

CONTROL AND SHUT-OFF VALVES IN SEISMIC VERSION

200 line



200 line

RV / UV 220 SP (Ex) RV / UV 230 SP (Ex)

two-way, single-seated,
control (shut-off) valve

RV 222 SP (Ex) RV 232 SP (Ex)

two-way, single-seated,
control valve with pressure-balanced plug

Control valves **200 line** are designed for regulation and shut-off of process liquid flow, for which seismic resistance of the device is required. The valves meet the conditions of **seismic resistance** in the sense of maintaining mechanical integrity and functionality after a seismic event with a response spectrum of up to $30 \text{ m}\cdot\text{s}^{-2}$ in all directions, in the band 0 to 33 Hz. Thus, they meet the requirements of **seismic classification 1b of fittings for nuclear energy according to OTT 87/91** and in non-nuclear applications meet the conditions for use in earthquake-prone areas with a maximum intensity of up to 9 degrees of the international scale EMS-98, or MSK-64 (9 bal).

Version Ex meets demands of II 1/2G IIC T6...T1 Ga/Gb acc. to ČSN EN ISO 80079-36 (9/2016) and ČSN EN 1127-1 ed.2 (1/2012). Flow characteristics, Kvs coefficients and leakage comply with international standards.

The maximal permissible operating pressures in behaviour with types of material and temperature are specified in the table on page 23 of this catalogue.

Control	hand wheel electromechanical actuators Auma
Application	RV / UV 2xx SP - heating, ventilation, power generation and chemical processing industries RV / UV 2xx SP Ex - gas and chemical industries
Process media	RV / UV 2xx SP - liquids, gases and vapours without abrasive particles e.g. water, steam, air and other media compatible with material of the valve inner parts RV / UV 2xx SP Ex - technical and fuel gases and inflammable liquids
Installation	To ensure a reliable regulation, the producer recommends to pipe a strainer in front of the valve into pipeline or ensure in any other way that process medium does not contain abrasive particles or impurities. The valve can be installed in any position except position when the actuator is under the valve body. The valve is to be piped the way so that the direction of medium flow will coincide with the arrows on the body. It is necessary to protect the actuator from excessive heat from the pipeline at medium temperatures above 150°C , e.g. by appropriately insulating the pipeline and valve and tilting the actuator from the vertical axis. When the valve is used as diverting, process medium flows through common valve port AB and split streams leave through valve ports A and B). Detailed informations are given in the instruction for installation and service.

Packings

O-ring EPDM

Packing is designed for non-aggressive media with temperature from 0°C to 140°C. Packing excels with its reliability and long time tightness. It has ability of sealing even if the valve stem is a bit damaged. Low frictional forces enables valve to be actuated with a low-linear-force actuator. Service life of sealing rings depends on operating conditions and it is more than 400 000 cycles on average.

DRSpack® (PTFE)

DRSpack® (Direct Radial Sealing Pack) is a packing with high tightness at both low and high operating pressure values.

It is the most used type of packing suitable for temperatures ranging from 0°C to 260°C. The pH range is from 0 to 14. The packing enables using of actuators with low linear force. The design enables an easy change of the whole packing. The average service life of DRSpack® is more than 500 000 cycles.

Graphite

This type of packing can be used for media with temperature up to 550°C and pH range: 0 to 14. Packing can be "sealed up" either by screwing the packing screw in or adding another sealing ring. In regard of intensive frictional forces, graphite packing is suitable for actuators with a sufficient linear force.

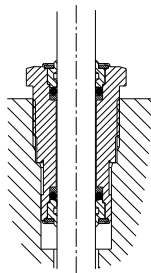

O-ring EPDM

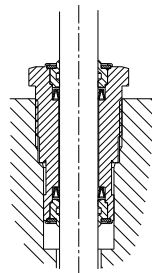

DRSpack® (PTFE)

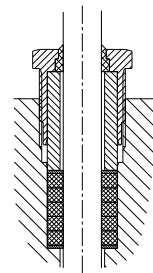

Graphite

Principles for plug type selection

V-ported plugs should not be used in supercritical differential pressures with inlet pressure $p \geq 0,4$ MPa and for regulation of saturated steam. In these cases we recommend to use a perforated plug. The perforated plug should be also used always when cavitation may occur due to a high differential pressure value or valve ports erosion caused by high speed of process medium flow. If the parabolic plug is used (because of small Kvs) for supercritical differential pressures, it is necessary to close both plug and seat with a hard metal overlay, i.e. stellite trim.

Rangeability

Rangeability is the ratio of the biggest value of flow coefficient to the smallest value. In fact it is the ratio (under the same conditions) of highest regulated flow rate value to its lowest value. The lowest or minimal regulated flow rate is always higher than 0.



RV / UV 2x0 SP

Control and
Shut-off valves
in seismic version

DN 15 to 400
PN 16, 25 and 40

Control valves **RV / UV 220 SP (Ex)** a **RV / UV 230 SP (Ex)**, and **RV / UV 2x0 SP (Ex)** are single-seated valves designed for regulation and shut-off of process liquid flow.

Technical data		RV / UV 220 SP (Ex)	RV / UV 230 SP (Ex)
Series			
Type of valve		Two-way, single-seated, control (shut-off) valve	
Nominal size range		DN 15 to 400	
Nominal pressure		PN 10, 16, 25, 40	
Body material		Cast steel 1.0619 (GP240GH) 1.7357 (G17CrMo5-5)	Stainless steel 1.4581 (GX5CrNiMoNb19-11-2)
Seat material	DN 15 - 50	1.4028 / 17 023.6	1.4571 / 17 348.4
DIN W.Nr./ČSN	DN 65 - 400	1.4027 / 42 2906.5	1.4581 / 42 2941.4
Plug material	DN 15 - 65	1.4021 / 17 027.6	1.4571 / 17 348.4
DIN W.Nr./ČSN	DN 80 - 150	1.4027 / 42 2906.5	1.4581 / 42 2941.4
	DN 200 - 400	1.4021 / 17 022.6	1.4581 / 42 2941.4
Stem material	DN 15 - 150	1.4305	1.4571
	DN 200 - 400	1.4923	1.4980
Operating temperature range		-50 to 500 °C - (request for negative temperature need to be specified in order)	
Face to face dimensions		Section 1 acc. to ČSN EN 558 (9/2017)	
Connection flanges		Acc. to ČSN EN 1092-1 (11/2018)	
Flange faces		Type B1 (raised-faced) or Type F (female) or Type D (groove) according to ČSN EN 1092-1 (11/2018)	
Type of plug		V-ported, contoured, perforated	
Flow characteristic		Linear, equal-percentage, LDMspline®, parabolic, on - off	
Kvs value		0.01 to 1600 m ³ /h	
Leakage rate		Class III. acc. to ČSN EN 1349 (7/2010) (<0.1% Kvs) for c. valves with metal-metal seat sealing Class IV. acc. to ČSN EN 1349 (7/2010) (<0.01% Kvs) for c. valves with metal-PTFE seat sealing Class IV. acc. to ČSN-EN 1349 (7/2010) (<0.01% Kvs) for shut-off valve	
Leakage rate for Ex version		RV 2xx Class IV. acc. to ČSN EN 1349 (7/2010) (<0.01% Kvs); UV 2xx Rate C acc. to ISO 5208:2008	
Rangeability r		50 : 1	
Packing		O - ring EPDM t _{max} =140°C, DRSpack®(PTFE) t _{max} =260°C, Exp. graphite, bellows t _{max} =500°C	
Seismic resistance		0 to 33 Hz, 30 m.s ⁻²	

Kvs values and differential pressures Δp_{max} [MPa] of valves DN 15 - 150

Δp_{max} value is the valve max. differential pressure when open - close function is always guaranteed. In regard of service life of seat and plug, it is recommended so that permanent differential pressure would not exceed 1.6 MPa. Otherwise it is suitable to use perforated plug (Δp up to 4,0 MPa), or sealing surfaces of seat and plug with a hard metal overlay (Δp up to 2,5 MPa).

For further information on actuating, see actuators' catalogue sheets		Actuating (actuator)										Auma		Hand wheel	
		Marking in valve specification No.										EA...		Rxx	
		Linear force										5 kN			
DN	H	Kvs [m ³ /h]									Δp_{max} [MPa]		Δp_{max} [MPa]		
		1	2	3	4	5	6	7	8	9	met PTFE	met PTFE	met PTFE	met PTFE	
15	16	---	2.5 ¹⁾	1.6 ¹⁾	1.0 ¹⁾	0.6 ¹⁾	0.4 ¹⁾	0.25 ¹⁾	0.16 ³⁾	0.1 ³⁾	4.00	---	4.00	4.00	
15		4.0 ¹⁾	---	---	---	---	---	---	---	---	4.00	---	4.00	4.00	
20		---	---	2.5 ¹⁾	1.6 ¹⁾	1.0 ¹⁾	0.6 ¹⁾	---	---	---	4.00	---	4.00	4.00	
20		---	4.0 ¹⁾	---	---	---	---	---	---	---	4.00	---	4.00	4.00	
20		6.3 ¹⁾	---	---	---	---	---	---	---	---	4.00	---	4.00	4.00	
25		---	---	---	2.5 ¹⁾	1.6 ¹⁾	---	---	---	---	4.00	---	4.00	4.00	
25		10.0	6.3 ²⁾	4.0 ²⁾	---	---	---	---	---	---	4.00	4.00	4.00	4.00	
32		---	---	---	4.0 ¹⁾	---	---	---	---	---	4.00	---	4.00	4.00	
32		16.0	10.0	6.3 ²⁾	---	---	---	---	---	---	4.00	4.00	4.00	4.00	
40		25.0	16.0	10.0	---	---	---	---	---	---	2.90	3.15	4.00	4.00	
50	25	40.0	25.0	16.0	---	---	---	---	---	1.69	1.88	3.80	4.00		
65		63.0	40.0	25.0	---	---	---	---	---	---	1.00	1.15	2.30	2.45	
80	40	100.0	63.0	40.0	---	---	---	---	---	---	---	---	2.54	2.66	
100		160.0	100.0	63.0	---	---	---	---	---	---	---	---	1.62	1.72	
125		250.0	160.0	100.0	---	---	---	---	---	---	---	---	1.03	1.12	
150		360.0	250.0	160.0	---	---	---	---	---	---	---	---	0.71	0.78	

For further information on actuating, see actuators' catalogue sheets		Actuating (actuator)							Auma		Auma		Auma	
		Marking in valve specification No.							EA...		EA...		EA...	
		Linear force							7,5 kN		10 kN		15 kN	
DN	H	Kvs [m ³ /h]						Δp_{max} [MPa]		Δp_{max} [MPa]		Δp_{max} [MPa]		
		1	2	3	4	5	6	7	met PTFE	met PTFE	met PTFE	met PTFE		
50	25	40.0	25.0	16.0	---	---	---	---	2.76	2.95	3.82	4.00	---	---
65		63.0	40.0	25.0	---	---	---	---	1.65	1.80	2.30	2.45	---	---
80	40	100.0	63.0	40.0	---	---	---	---	1.01	1.13	1.46	1.58	2.36	2.48
100		160.0	100.0	63.0	---	---	---	---	0.63	0.73	0.92	1.02	1.50	1.61
125		250.0	160.0	100.0	---	---	---	---	0.39	0.47	0.58	0.66	0.96	1.04
150		360.0	250.0	160.0	---	---	---	---	0.26	0.33	0.39	0.46	0.66	0.73

- 1) parabolic plug
 - 2) V-ported plug with linear characteristic, parabolic plug with equal-percentage, LDMspline® or parabolic characteristic
 - 3) valve with micro-throttling trim. Version with Kvs 0.01 to 0.063 m³/hour is possible after agreement with the producer.
- LDMspline® or parabolic characteristic from Kvs ≥ 1.0 , equal-percentage, from Kvs ≥ 0.4
- Perforated plug available only with Kvs values in shadowed frames with the following restrictions:
- Kvs values 2.5 to 1.6 m³/hour available with linear characteristic only
 - Perforated plug with Kvs value acc. to column No. 2 available with linear or parabolic characteristic only.

Max. differential pressure Δp for valves PN 16 must be 1.6 MPa

metal - version with metal - metal seat sealing
PTFE - version with metal - PTFE seat sealing (is not applicable to contoured plugs)

Max. differential pressures specified in table apply to PTFE and O-ring packing. Δp_{max} for bellows must be consulted with the producer.

Values Δp_{max} are set for the most unfavourable pressure ratios on the valve PN 40, but in concrete cases the real Δp_{max} value can be higher than values specified in the table above.

Kvs values and differential pressures Δp_{max} [MPa] of valves DN 200 - 400 with V-ported plugs (flow direction below plug) for electromechanical actuators

Δp_{max} value is the valve max. differential pressure when open - close function is always guaranteed. In regard of service life of seat and plug, it is recommended so that permanent differential pressure would not exceed 1.6 MPa. Otherwise it is suitable to use perforated plug (Δp up to 4,0 MPa), or sealing surfaces of seat and plug with a hard metal overlay (Δp up to 2,5 MPa).

For further information on actuating, see actuators' catalogue sheets *) max. DN 300 Ds - seat diameter Max. differential pressures specified in table are valid for seat sealing metal-metal and hard metal overlay on sealing surf. Max. differential pressure Δp for valves PN 16 (PN 25) must be 1,6 MPa (2,5 MPa).			Actuating (actuator)					Auma	Auma	Auma	Hand wheel
			Marking in valve specification No.					EA...	EA...	EA...	Rxx
			Linear force					15 kN	20 kN	32 kN	
			Kvs [m³/h]					packing	packing	packing	packing
DN	Ds	H	1	2	3	4	5	graphite PTFE	graphite PTFE	graphite PTFE	graphite PTFE
200	100	80	---	---	250	160	100	1.12 1.46	1.71 2.05	3.14 3.47	2.31 2.64
	150		---	400	---	---	---	0.48 0.63	0.75 0.90	1.39 1.54	1.01 1.17
	200		570	---	---	---	---	0.26 0.34	0.41 0.50	0.77 0.86	0.56 0.65
250	150	80	---	---	400	250	160	0.41 0.59	0.68 0.86	1.33 1.50	0.95 1.13
	200		---	630	---	---	---	0.22 0.32	0.37 0.47	0.74 0.84	0.52 0.62
	230		800	---	---	---	---	0.16 0.23	0.27 0.35	0.55 0.63	0.39 0.46
300	200	80	---	---	630	---	---	0.22 0.32	0.37 0.47	1.74 0.84	0.52 0.62
	230		---	800	---	---	---	0.16 0.23	0.27 0.35	0.55 0.63	0.39 0.46
	250		1000	---	---	---	---	0.13 0.19	0.23 0.29	0.46 0.53	0.33 0.39
400	200	100	---	---	630	---	---	0.22 0.32	0.37 0.47	0.74 0.84	0.52 0.62
	250		---	1000	---	---	---	0.13 0.19	0.23 0.29	0.46 0.53	0.33 0.39
	330		1600	---	---	---	---	0.07 0.10	0.12 0.16	0.26 0.30	0.18 0.22

Kvs values and differential pressures Δp_{max} [MPa] of valves DN 200 - 400 with perforated plugs (flow direction above plug) for electromechanical actuators

For further information on actuating, see actuators' catalogue sheets *) max. DN 300 Ds - seat diameter It is not possible to delivery perforated plugs for Kvs acc. to the column No.1, for Kvs acc. to the column No.2 it is possible only with linear or parabolic characteristic. For another columns without limitation. Max. differential pressures specified in table apply to PTFE and graphite packing. Max. differential pressure Δp for valves PN 16 (PN 25) must be 1,6 MPa (2,5 MPa).			Actuating (actuator)					Auma	Auma	Auma	Hand wheel
			Marking in valve specification No.					EA...	EA...	EA...	Rxx
			Linear force					15 kN	20 kN	32 kN	
			Kvs [m³/h]					packing	packing	packing	packing
DN	Ds	H	1	2	3	4	5	graphite PTFE	graphite PTFE	graphite PTFE	graphite PTFE
200	200	80	---	400	250	160	100	0.26 0.34	0.41 0.50	0.77 0.86	1.00
250	230	80	---	630	400	250	160	0.16 0.23	0.27 0.35	0.55 0.63	0.75
300	250	80	---	800	630	400	250	0.13 0.19	0.23 0.29	0.46 0.53	0.60
400	330	100	---	1000	630	400	250	0.07 0.10	0.12 0.16	0.26 0.30	0.35

Dimensions and weights of valves made of spheroidal cast iron for the type RV / UV 2x0 SP (Ex), DN 200 - 400

DN	PN 10						PN 16						PN 25						
	D ₁ mm	D ₂ mm	D ₃ mm	d mm	n	a mm	D ₁ mm	D ₂ mm	D ₃ mm	d mm	n	a mm	D ₁ mm	D ₂ mm	D ₃ mm	d mm	n	a mm	
200	340	295	268		8	24	340	295	268	22		24	360	310	278	26			
250	395	350	320	22	12	26	405	355	320	26	12	26	425	370	335	30		12	32
300	445	400	370		12	26	460	410	378	26		28	485	430	395	30		16	34
400	565	515	482	26	16	26	580	525	490	30	16	32	620	550	505	36			40

DN	PN 40							PN 10-40									
	D ₁ mm	D ₂ mm	D ₃ mm	d mm	n	a mm	D mm	D ₅ mm	M mm	L mm	V ₁ mm	V ₂ mm	V ₃ mm	V ₄ mm	H mm	m kg	
200	375	320	285	30	12	34	200	M20x1.5	150	600	203	262	422	160	80	220	
250	450	385	345	33	12	38	250			730	253	346	506			390	
300	515	450	410	33	16	42	300			850	296	395	555			570	
400	660	585	535	39	16	50	400			1100	382	512	672			1170	

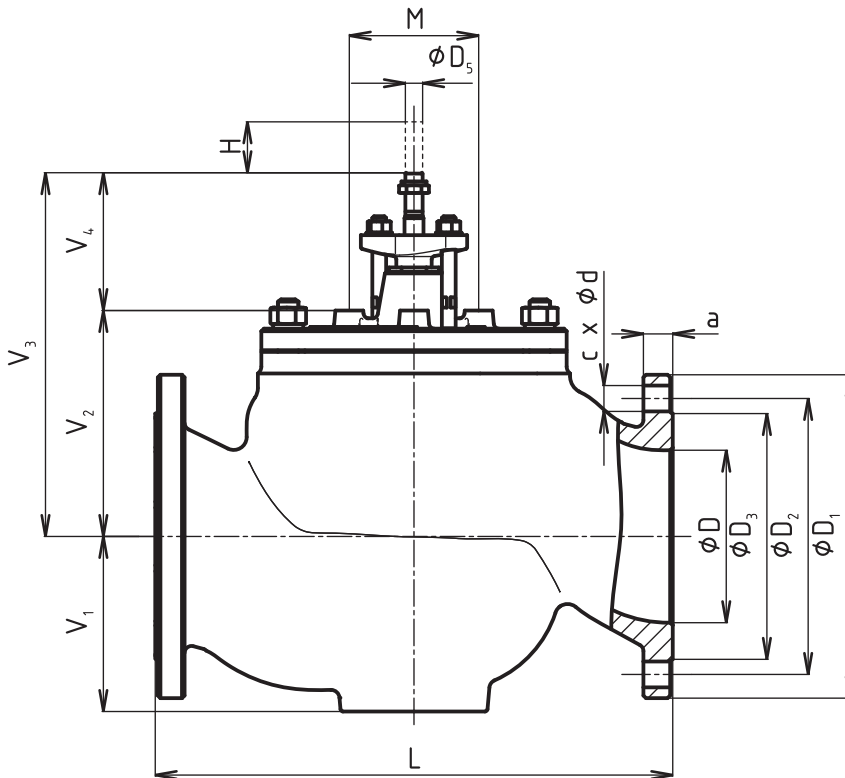



RV 2x2 SP

Control valves,
pressure-balanced,
in seismic version

DN 25 - 600
PN 16, 25 and 40

Control valves **RV 212 SP (Ex)**, **RV 222 SP (Ex)** and **RV 232 SP (Ex)**, further only **RV 2x2 SP (Ex)** are single-seated valves with pressure-balanced plug designed for regulation of process liquids flow. This design of the valves allows control at high pressure drops, even at low forces of the used actuators.

Technical data		RV 222 SP (Ex)	RV 232 SP (Ex)
Series		RV 222 SP (Ex)	RV 232 SP (Ex)
Type of valve		Two-way, single-seated, control valve with pressure-balanced plug	
Nominal size range		DN 25 to 600	
Nominal pressure		PN 10, 16, 25, 40	
Body material		Cast steel 1.0619 (GP240GH) 1.7357 (G17CrMo5-5)	Stainless steel 1.4581 (GX5CrNiMoNb19-11-2)
Seat material	DN 25 - 50	1.4028 / 17 023.6	1.4571 / 17 347.4
DIN W.Nr./ČSN	DN 65 - 400	1.4027 / 42 2906.5	1.4581 / 42 2941.4
Plug material	DN 25 - 65	1.4021 / 17 027.6	1.4571 / 17 347.4
DIN W.Nr./ČSN	DN 80 - 150	1.4027 / 42 2906.5	1.4581 / 42 2941.4
	DN 200 - 600	1.4021 / 17 022.6	1.4581 / 42 2941.4
Stem material	DN 25 - 150	1.4305	1.4571
	DN 200 - 600	1.4923	1.4980
Operating temperature range		-50 to 500 °C - (negative temperature requirement must be stated in the order)	
Face to face dimensions		Section 1 acc. to ČSN EN 558 (9/2017)	
Connection flanges		Acc. to ČSN EN 1092-1 (11/2018)	
Flange faces		Type B1 (raised-faced) or Type F (female) or Type D (groove) acc. to ČSN EN 1092-1 (11/2018)	
Type of plug		V-ported, perforated	
Flow characteristic		Linear, equal-percentage, LDMspline [®] , parabolic	
Kvs value		4 to 4000 m ³ /h	
Leakage rate		Class III. acc. to ČSN-EN 1349 (<0.1% Kvs) for c. valves with metal-metal seat sealing (7/2010) Class IV. acc. to ČSN-EN 1349 (<0.01% Kvs) for c. valves with metal-PTFE seat sealing (7/2010)	
Leakage rate for Ex version		RV 2xx class IV. acc. to ČSN EN 1349 (7/2010) (<0.01% Kv)	
Rangeability r		50 : 1	
Packing		O - ring EPDM t _{max} = 140 °C, DRSpack [®] (PTFE) t _{max} = 260 °C, Exp. graphite t _{max} = 500 °C	
Seismic resistance		0 to 33 Hz, 30 m.s ⁻²	

Kvs values and differential pressures Δp_{\max} [MPa] of valves DN 25 - 150

Δp_{\max} value is the valve max. differential pressure when open - close function is always guaranteed. In regard of service life of seat and plug, it is recommended so that permanent differential pressure would not exceed 1.6 MPa. Otherwise it is suitable to use perforated plug (Δp up to 4,0 MPa), or sealing surfaces of seat and plug with a hard metal overlay (Δp up to 2,5 MPa).

For further information on actuating, see actuators' catalogue sheets			Actuating (actuator)					Auma	Hand wheel
			Marking in valve specification No.					EA...	Rxx
			Linear force					5 kN	
DN	H	Kvs [m³/h]					Δp_{\max}	Δp_{\max}	
		1	2	3	4	5			
25	16	10.0	6.3 ¹⁾	4.0 ¹⁾	2.5 ¹⁾	1.6 ¹⁾	---	4.00	
32		16.0	10.0	6.3 ¹⁾	4.0 ¹⁾	2.5 ¹⁾	---	4.00	
40		25.0	16.0	10.0	6.3 ¹⁾	4.0 ¹⁾	---	4.00	
50	25	40.0	25.0	16.0	10.0	6.3 ¹⁾	4.00	4.00	
65		63.0	40.0	25.0	16.0	10.0	4.00	4.00	
80	40	100.0	63.0	40.0	25.0	16.0	4.00	4.00	
100		160.0	100.0	63.0	40.0	25.0	4.00	4.00	
125		250.0	160.0	100.0	63.0	40.0	4.00	4.00	
150		360.0	250.0	160.0	100.0	63.0	4.00	4.00	

1) linear characteristic only

Valves RV 2x2 can be optionally assembled with all the actuators specified in catalogue sheet RV / UV 2x0. Max. differential pressures specified in table apply to PTFE and O-ring packing. Δp_{\max} for bellows must be consulted with the producer.

Perforated plug available only with Kvs values in shadowed frames with the following restrictions:

- Perforated plug with Kvs value acc. to column No. 2 available with linear or parabolic characteristic only
- Max. differential pressure Δp for valves PN 16 must be 1.6 MPa.

Kvs values and differential pressures Δp_{\max} [MPa] of valves DN 200 - 600

Δp_{\max} value is the valve max. differential pressure when open - close function is always guaranteed. In regard of service life of seat and plug, it is recommended so that permanent differential pressure would not exceed 1.6 MPa. Otherwise it is suitable to use perforated plug (Δp up to 4,0 MPa), or sealing surfaces of seat and plug with a hard metal overlay (Δp up to 2,5 MPa).

For further information on actuating, see actuators' catalogue sheets			Actuating (actuator)					Auma	Auma	Auma	Hand wheel
			Marking in valve specification No.					EA...	EA...	EA...	Rxx
			Linear force								
			Kvs [m³/h]					packing	packing	packing	packing
DN	Ds	H	1	2	3	4	5	graphite PTFE	graphite PTFE	graphite PTFE	graphite PTFE
200	200	80	570	400	250	160	100	4.00	---	---	4.00
250	230	80	800	630	400	250	160	---	4.00	---	4.00
300	250	80	1000	800	630	400	250	---	4.00	---	4.00
400	330	100	1600	1000	630	400	250	---	4.00	---	4.00
500	420	100	2800	2000	1600	1000	630	---	---	4.00	---
600	500	120	4000	2500	1600	1000	630	---	---	4.00	---

It is not possible to delivery perforated plugs for Kvs acc. to the column No.1, for Kvs acc. to the column No.2 it is possible only with linear or parabolic characteristic. For another columns without limitation.

Max. differential pressures specified in table apply to PTFE and graphite packing.

Max. differential pressure p for valves PN 16 (PN 25) must be 1,6 MPa (2,5 MPa).

Dimensions and weights of valves made of cast steel and stainless steel for the type RV 222 SP (Ex), RV 232 SP (Ex) DN 25 - 150

DN	PN 10-16					PN 25-40					PN 10-40																
	D ₁ mm	D ₂ mm	D ₃ mm	d mm	n	D ₁ mm	D ₂ mm	D ₃ mm	d mm	n	D mm	D ₄ mm	D ₅ mm	L mm	V ₁ mm	V ₂ mm	V ₃ mm	V ₄ mm	a mm	H mm	m kg						
25	115	85	68	14	4	115	85	68	14	4	25	65	M10x1	160	51	73	162	89	18	16	8.5						
32	140	100	78	14		140	100	78	14		32			180	54	73	162		18		10						
40	150	110	88	14		150	110	88	14		40			200	58	73	162		18		10						
50	165	125	102	14		165	125	102	18		50			230	70	104	193		20		21						
65	185	145	122	18	8 ¹⁾	185	145	122	18	8	65	65	M10x1	290	75	104	193	107	22	25	27						
80	200	160	138	18		200	160	138			22			80	310	85	138		245	24	42						
100	220	180	158	22	8	235	190	162	22	8	100	M16x1,5	350	93	138	245	107	24	40	50							
125	250	210	188			26	270	220			188									26	125	400	105	157	264	26	84
150	285	240	212			22	300	250			218									26	150	480	118	174	281	28	103

¹⁾ According to EN 1092-1 standard, flanges with 4 holes may be supplied. In case flanges with 4 holes are required specifically, this requirement must be declared in the order.

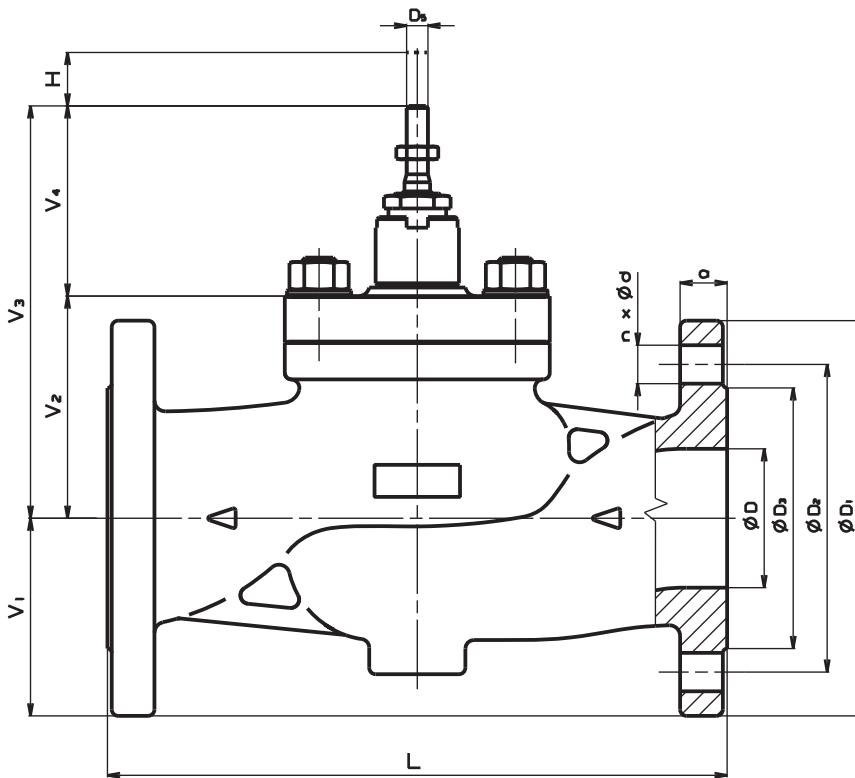

Dimensions and weights of valves made of cast steel and stainless steel for the type RV 222 SP (Ex), RV 232 SP (Ex), DN 200 - 600

DN	PN 10						PN 16						PN 25					
	D ₁ mm	D ₂ mm	D ₃ mm	d mm	n	a mm	D ₁ mm	D ₂ mm	D ₃ mm	d mm	n	a mm	D ₁ mm	D ₂ mm	D ₃ mm	d mm	n	a mm
200	340	295	268	22	8	24	340	295	268	22	12	24	360	310	278	26	12	30
250	395	350	320	22	12	26	405	355	320	26	12	26	425	370	335	30	12	32
300	445	400	370	22	12	26	460	410	378	26	12	28	485	430	395	30	16	34
400	565	515	482	26	16	26	580	525	490	30	16	32	620	550	505	36	16	40
500	670	620	585	26	20	28	715	650	615	33	20	44	730	660	615	36	20	48
600	780	725	685	30	20	34	840	770	725	36	20	54	845	770	720	39	20	58

DN	PN 40						PN 10-40									
	D ₁ mm	D ₂ mm	D ₃ mm	d mm	n	a mm	D mm	D ₅ mm	M mm	L mm	V ₁ mm	V ₂ mm	V ₃ mm	V ₄ mm	H mm	m kg
200	375	320	285	30	12	34	200	M20x1.5	150	600	203	262	422	160	80(63) ¹⁾	232
250	450	385	345	33	12	38	250			730	253	346	506	160	80	395
300	515	450	410	33	16	42	300			850	296	395	555	160	80	596
400	660	585	535	39	16	50	400			1100	382	512	672	160	100	1213
500	755	670	615	42	20	57	400	M30x2	300	1250	510	595	805	210	100	2200
600	890	795	735	48	20	72	580			1450	590	675	885	210	120	3500

¹⁾ DN 200 with graphite balancing - stroke = 63 mm

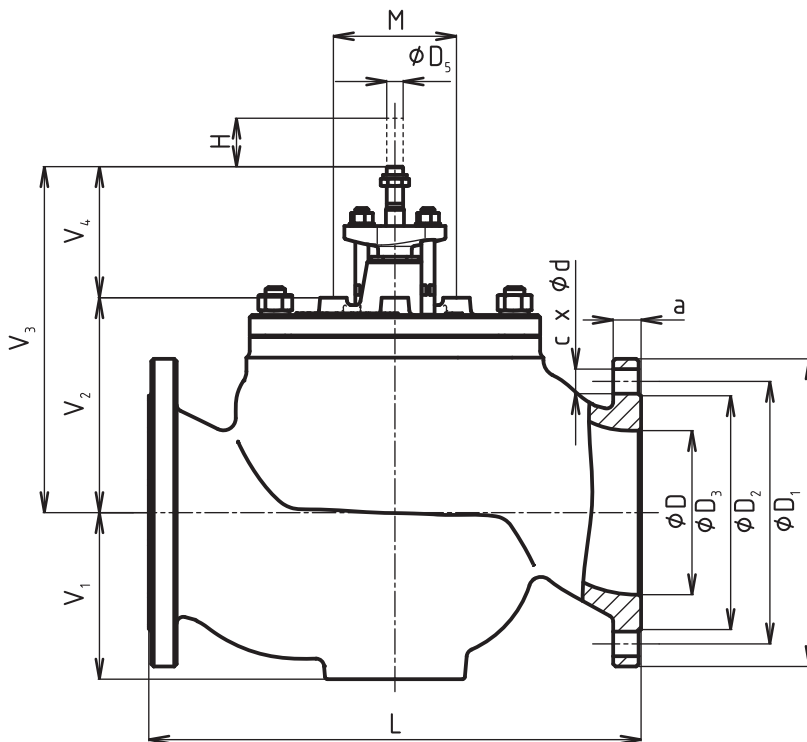

Valve complete specification No. for ordering RV / UV 2x0 SP (Ex) and RV 2x2 SP (Ex)

		XX	XXX	XXX	XXXX	XX	- XX	/ XXX	- XXX	XXXX
1. Valve	Control valve	RV								
	Shut-off valve	UV								
2. Series	Valves made of cast steel 1.0619, 1.7357		2 2							
	Valves made of stainless steel 1.4581		2 3							
	Direct valve		0							
	Pressure -balanced valve		2							
3. Actuating	Electric actuator			E X X						
	Hand wheel			R X X						
4. Connection	Raised flange				1					
	Female flange				2					
	Flange with groove				3					
5. Body material <i>(Operating temp. ranges are specified in parentheses)</i>	Sphr. cast iron EN-JS 1025 (-10 to 400 °C)				1					
	CrMo steel 1.7357 (-10 to 500 °C)				7					
	Stainless steel 1.4581 (-10 to 500 °C)				8					
	Other material on request				9					
6. Seat sealing ¹⁾ DN 25 to 400; t _{max} = 260 °C	Metal - metal				1					
	Soft sealing (metal - PTFE) ¹⁾				2					
	Hard metal overlay on sealing surfaces				3					
	Balanced by graphite, metal - metal				5					
	Balanced by graphite, hard metal overlay				7					
	Balanced with metal sealing cuff, hard metal overlay				8					
7. Packing ³⁾ Not appl. to Ex version	O - ring EPDM ³⁾				1					
	DRSpack® (PTFE)				3					
	Exp. graphite				5					
8. Flow characteristic ⁴⁾ Only for UV 2x0	Linear					L				
	Equal-percentage in straight way					R				
	LDMspline®					S				
	On-off ⁴⁾					U				
	Parabolic					P				
	Linear - perforated plug					D				
	Equal-percentage - perforated plug					Q				
Parabolic - perforated plug					Z					
9. Kvs	Column No. acc. to Kvs value table					X				
10. Nominal pressure PN ⁷⁾ DN 200 - 600	PN 10 ⁷⁾						10			
	PN 16						16			
	PN 25 ⁷⁾						25			
	PN 40						40			
11. Max. operating temp.	Acc. to version 140 - 500°C							XXX		
12. Nominal size DN	DN								XXX	
13. Version	Seismically resistant									SP
	Non - explosive, seismically resistant									SPEX
	Oxygen, seismically resistant									SPOX

Ordering example: RV220 EAC 1113 L1 40/220-065SP

For marking of actuators in specification code, refer to table on page 23 of this catalogue

Valves RV / UV 2x0 SP (Ex)

Section of valve
with V-ported plug

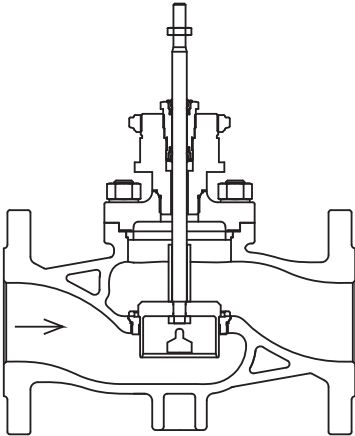

Section of valve
with perforated plug

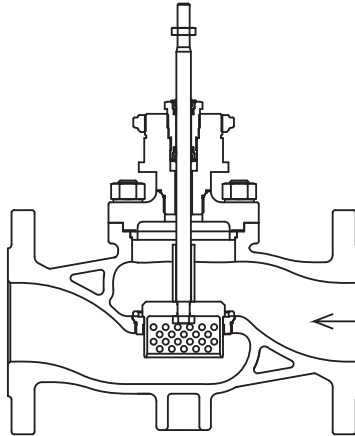

Valves RV 2x2 SP (Ex)

Section of pressure-balanced valve
with V-ported plug

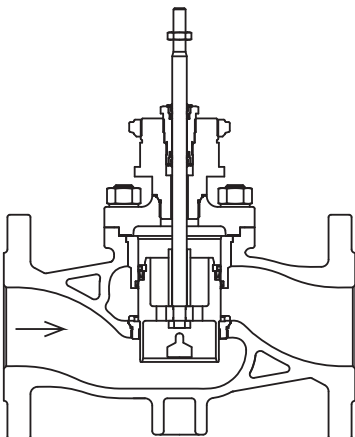

Section of pressure-balanced valve
with perforated plug

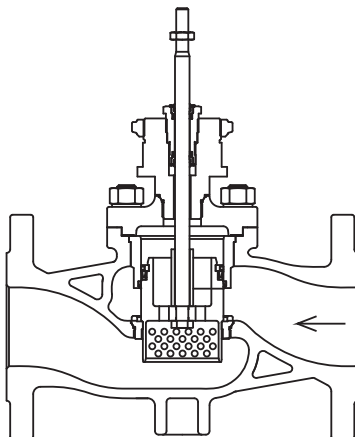



Electric actuators

Auma

**SA 07.2, SA Ex 07.2,
SAR 07.2, SAR Ex 07.2,
SA 07.6, SA Ex 07.6,
SAR 07.6, SAR Ex 07.6**

marking in type number:

**EAA, EAB, EAC, EAD
EAE, EAF, EAG, EAH**

Technical data								
Type	SA 07.2	SA Ex 07.2	SAR 07.2	SAR Ex 07.2	SA 07.6	SA Ex 07.6	SAR 07.6	SAR Ex 07.6
Marking in valve spec. No.	EAA	EAB	EAC	EAD	EAE	EAF	EAG	EAH
Voltage	3-phase ~ 380 or 400 V AC (1-phase ~ 230 V AC cannot be used - high weight)							
Frequency	50 Hz							
Power consumption	see specification table							
Control	3 - point or with signal 4 - 20 mA							
Nominal force	10 Nm~5 kN; 15 Nm~7,5 kN; 20 Nm~10 kN				30 Nm~15 kN; 40 Nm~20 kN			
Travel	acc. to used valve 16, 20, 40 mm				acc. to used valve 40, 80 mm			
Enclosure	IP 68							
Process medium max. temp.	acc. to used valve							
Ambient temperature range	-40 to 80°C	-20 to 60°C	-40 to 60°C	-20 to 60°C	-40 to 80°C	-20 to 60°C	-40 to 60°C	-20 to 60°C
Ambient humidity range	100 %							
Weight	20 - 33 kg				21 - 33kg			
Vibration resistance dile EN 60068-2-6	AUMA NORM: 2g, 10-200Hz AUMA MATIC: 1g, 10-200Hz AUMATIC: 1g, 10-200Hz							

→ **Note:** Specifications and technical data are for information only.

Detailed technical informations can be found in producer's data sheet or on the website www.auma.com

Specification of Auma actuators					SA	X	XX	07.X
Type					SA			
Duty					SA	R		
Version							Ex	
Actuator size								07.2 07.6
Output shaft type A (thread TR 16x4 LH, connection flange F07) ... for RV 2xx DN 15 to 150								
Output speed [ot/min]	Tripping torque	SA 07.2	SAR 07.2	Motor power [kW]	SA 07.2	SA Ex 07.2	SAR 07.2	SAR Ex 07.2
		SA Ex 07.2	SAREx 07.2		S2-15min	S2-15min	S4-25%	S4-25%
4		10-30 Nm	15-30 Nm		0,02	0,02	0,02	0,02
5,6				0,02	0,02	0,02	0,02	
8				0,04	0,04	0,04	0,04	
11				0,04	0,04	0,04	0,04	
16				0,06	0,06	0,06	0,06	
22				0,06	0,06	0,06	0,06	
32				0,10	0,10	0,10	0,10	
45				0,10	0,10	0,10	0,10	
Output shaft type A (thread TR 20x4 LH, flange F10) ... for RV 2xx DN 80 to 400								
Output speed [ot/min]	Tripping torque	SA 07.6	SAR 07.6	Motor power [kW]	SA 07.6	SA Ex 07.6	SAR 07.6	SAR Ex 07.6
		SA Ex 07.6	SAREx 07.6		S2-15min	S2-15min	S4-25%	S4-25%
4		20-60 Nm	30-60 Nm		0,03	0,03	0,03	0,03
5,6				0,03	0,03	0,03	0,03	
8				0,06	0,06	0,06	0,06	
11				0,06	0,06	0,06	0,06	
16				0,12	0,12	0,12	0,12	
22				0,12	0,12	0,12	0,12	
32				0,20	0,20	0,20	0,20	
45				0,20	0,20	0,20	0,20	

Accessories

- 2 TANDEM switches
- Gearing for signalisation of position
- Mechanical position indicator
- Potentiometer 1x200 Ω
- Electronic position transmitter RWG (potentiometer included), 4 - 20 mA, 2-wire
- Electronic position transmitter RWG (potentiometer included), 4 - 20 mA, 3/4-wire
- Inductive position transmitter IWG, 4 - 20 mA
- MATIC - or continuous control (specification of accessories acc. to catalogue of producer: IP 67; -25 to +70°C; ...), weight + 7 kg
- AUMATIC - or continuous control (specification of accessories acc. to catalogue of producer: IP 68; -25 to +70°C; ...), weight + 7kg

Other accessories acc. to catalogue of producer of actuators.

Dimensions of actuators Auma series 07.2 and 07.6

Normal version

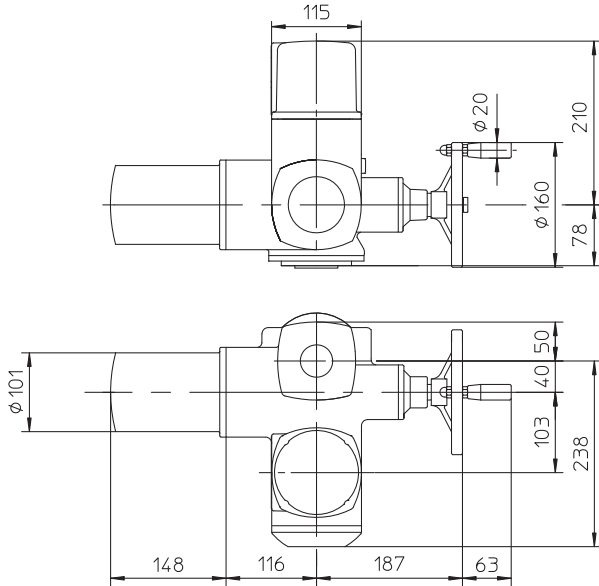

Version Ex norm

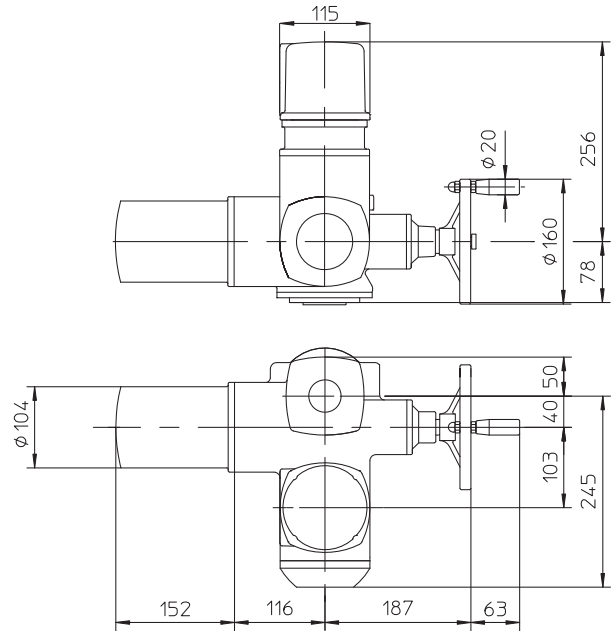

Version MATIC

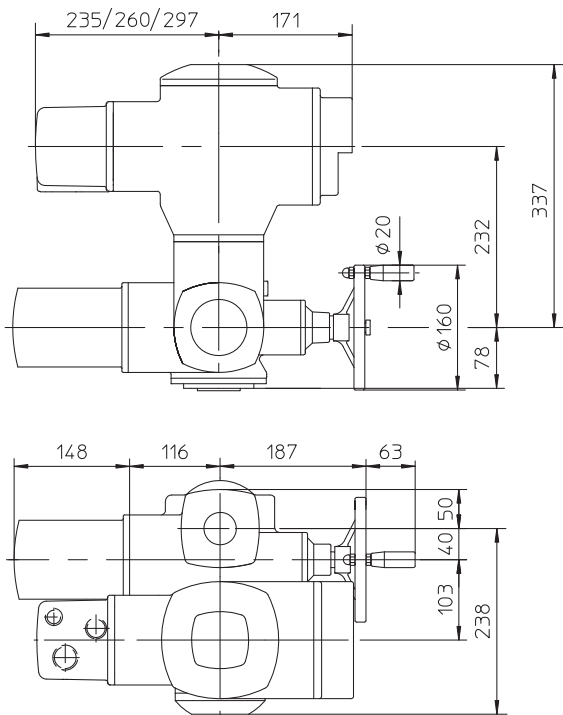

Version Ex MATIC

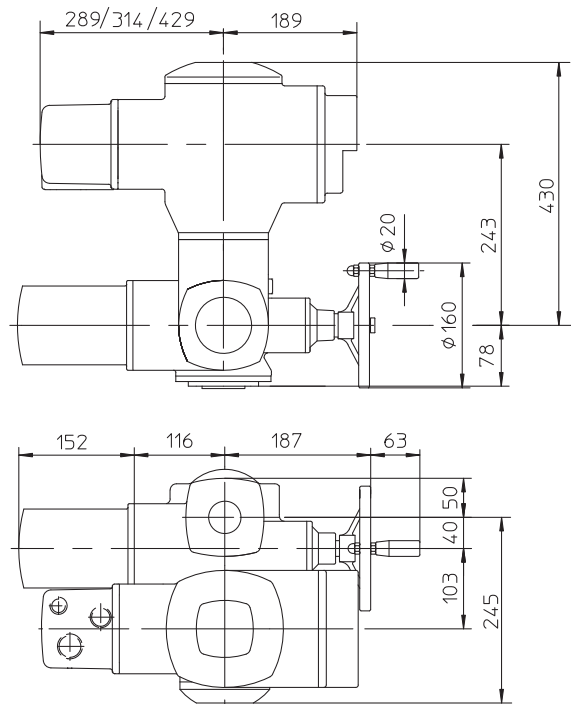

Version with AUMATIC

Version Ex AUMATIC

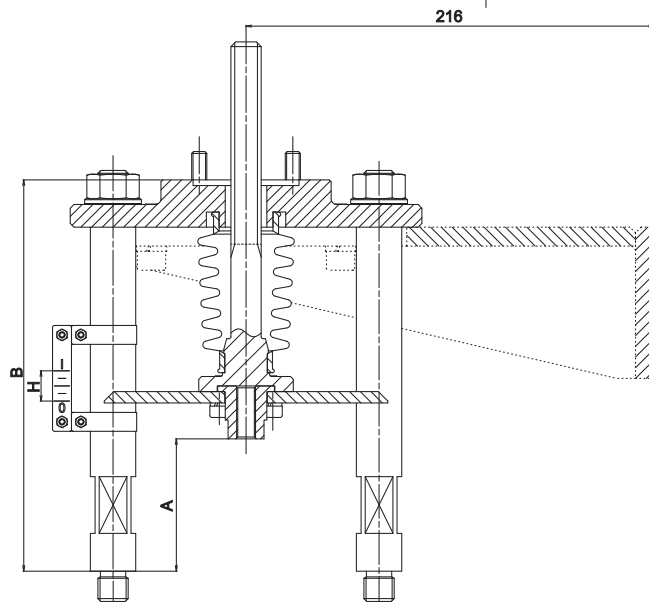
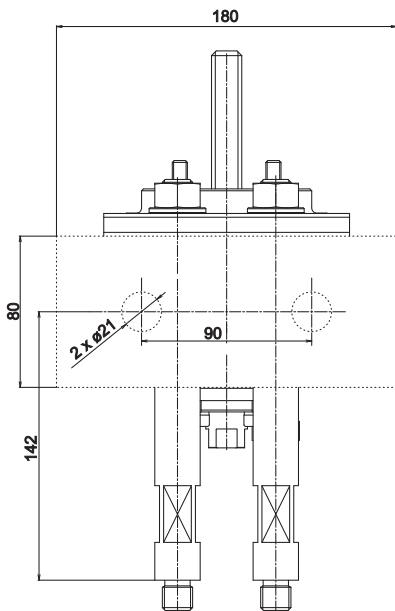
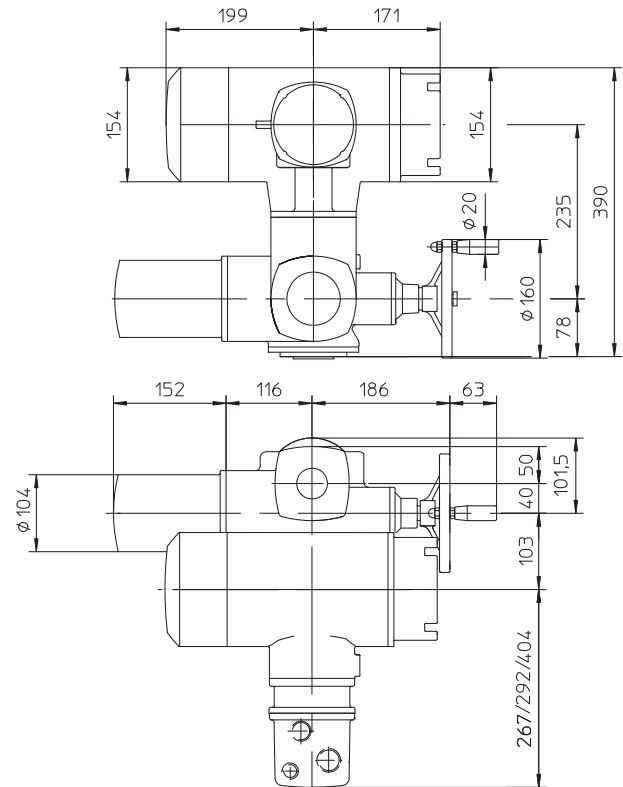
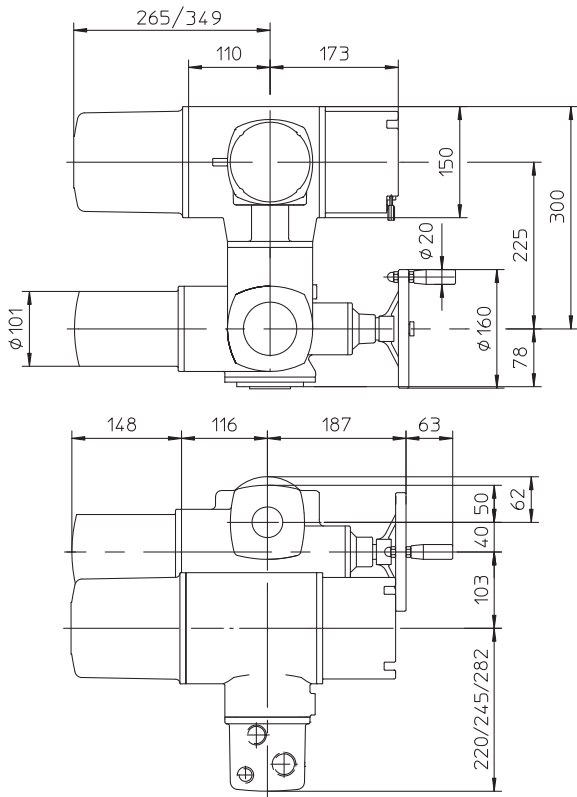

..... console required for DN15-32, all versions AUMA SAR 07.2 max. 33kg (Norm, Matic, Automatic, Ex), with exception DN 20-25 AUMA SAR 07.2 Norm max. 24,3kg, DN 32 AUMA SAR 07.2 Norm, Matic, Automatic max. 31kg (mimo Ex).

For valves	Number of columns	A	B	Weight
RV 2xx DN 15 to 65	4	70	207	~ 6 kg + ~ (6 kg console)
RV 2xx DN 80 to 150	4	80	245	~ 8 kg
RV 2xx DN 200 to 400	4	140	420	~ 15 kg

Output drive shaft A, F07

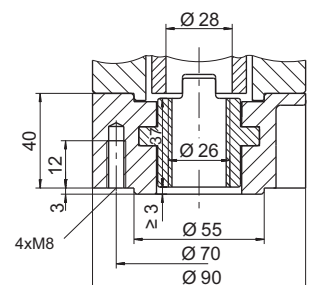



Electric actuators

Auma

SA 10.2, SA Ex 10.2
SAR 10.2, SAR Ex 10.2

marking in type number:

EAI, EAJ, EAK, EAL

Technical data				
Type	SA 10.2	SA Ex 10.2	SAR 10.2	SAR Ex 10.2
Marking in valve spec. No.	EAI	EAL	EAJ	EAK
Voltage	3-phase ~ 380 or 400 V AC (1-phase ~ 230 V AC not applicable - high weight)			
Frequency	50 Hz			
Power consumption	see specification table			
Control	3 - point or with signal 4 - 20 mA			
Nominal force	80 Nm ~ 21,6 kN; 100 Nm ~ 27 kN; 120 Nm ~ 32 kN			
Travel	80, 100 mm			
Enclosure	IP 68			
Process medium max. temp.	acc. to used valve			
Ambient temperature range	-40 to 80 °C	-20 to 60 °C	-40 to 60 °C	-20 to 60 °C
Ambient humidity range	100 %			
Weight	22 to 47 kg			
Vibration resistance acc. to EN 60068-2-6	AUMA NORM: 2g, 10-200Hz; AUMA MATIC: 1g, 10-200Hz; AUMATIC: 1g, 10-200Hz			

→ **Note:** Specifications and technical data are for information only.

Detailed technical informations can be found in producer's data sheet or on the website www.auma.com

Specification of Auma actuators

		SA	X	XX	10.2
Type		SA			
Duty	control ON - OFF		R		
Version	standard non-explosive			Ex	
Actuator size					10.2
Output drive shaft type A (thread TR 36x6 LH, flange F10) ... for RV 2xx DN 200 - 400					

Output speed [ot/min]	Tripping torque	SA 10.2	SAR 10.2	SA 10.2	SA Ex 10.2	SAR 10.2	SAR Ex 10.2
		SAEx10.2	SAREx10.2	S2-15min	S2-15min	S4-25%	S4-25%
4	40-120 Nm 60-120 Nm			0,06	0,09	0,09	0,09
5,6				0,06	0,09	0,09	0,09
8				0,12	0,18	0,18	0,18
11				0,12	0,18	0,18	0,18
16				0,25	0,37	0,37	0,37
22				0,25	0,37	0,37	0,37
32				0,40	0,75	0,75	0,75
45				0,40	0,75	0,75	0,75

Accessories

- 2 TANDEM switches
 - Gearing for signalisation of position
 - Mechanical position indicator
 - Potentiometer 1x200 Ω
 - MATIC - or continuous control (specification of accessories acc. to catalogue of producer: IP 67; -25 to +70°C; ...), weight + 7 kg
 - AUMATIC - or continuous control (specification of accessories acc. to catalogue of producer: IP 68; -25 to +70°C; ...), weight + 7kg
- Other accessories acc. to catalogue of producer of actuators.
- Electronic position transmitter RWG (potentiometer included), 4 - 20 mA, 2-wire
 - Electronic position transmitter RWG (potentiometer included), 4 - 20 mA, 3/4-wire
 - Inductive position transmitter IWG, 4 - 20 mA

Dimensions of actuators Auma series 10

Normal version

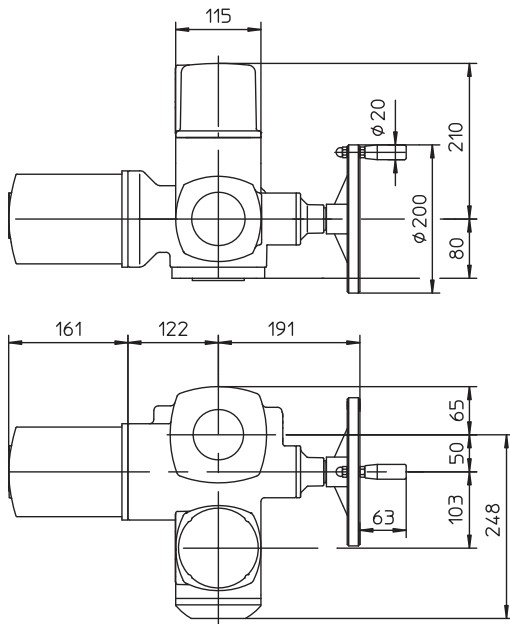

Ex norm version

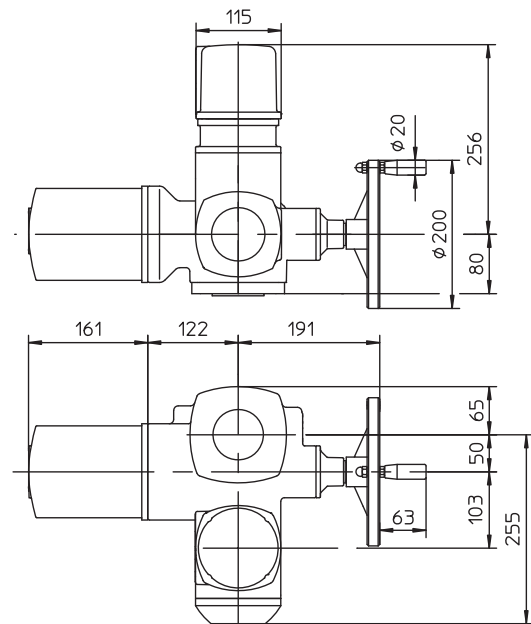

Version with MATIC

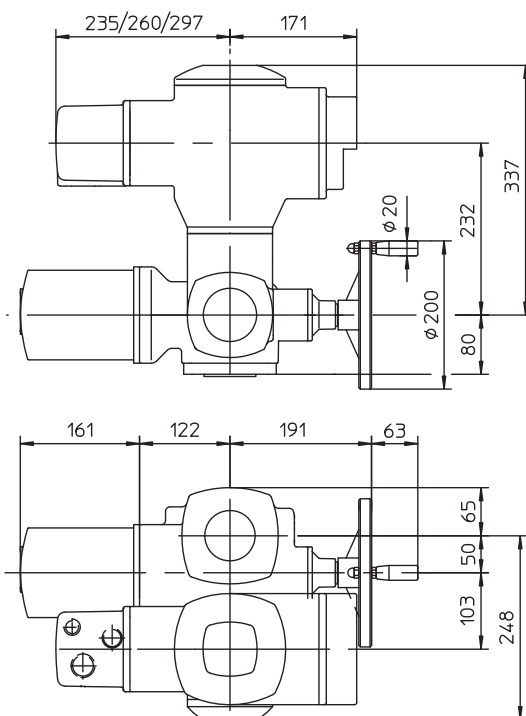

Version with Ex MATIC

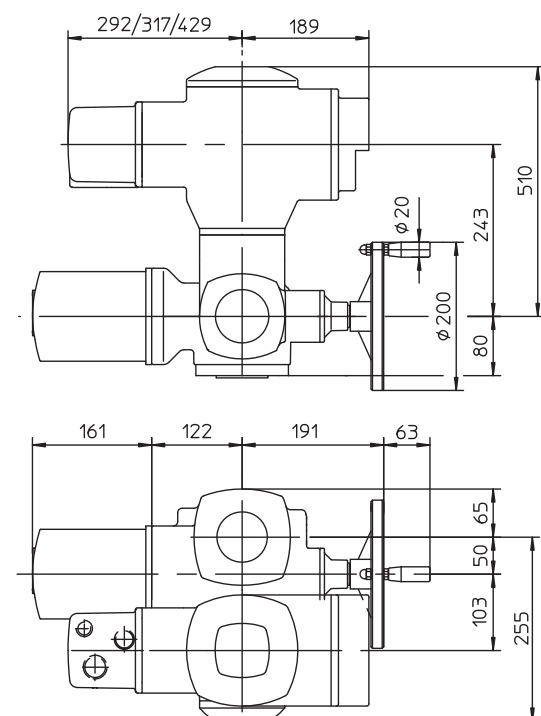

Version AUMATIC

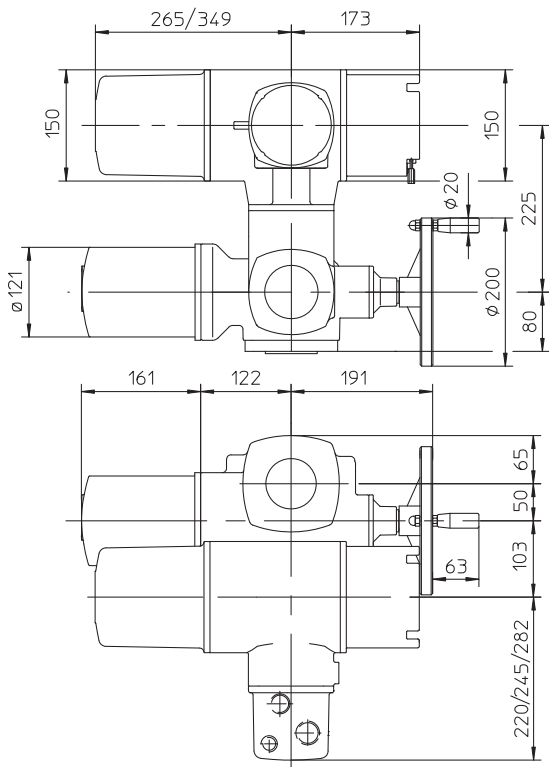

Version Ex AUMATIC

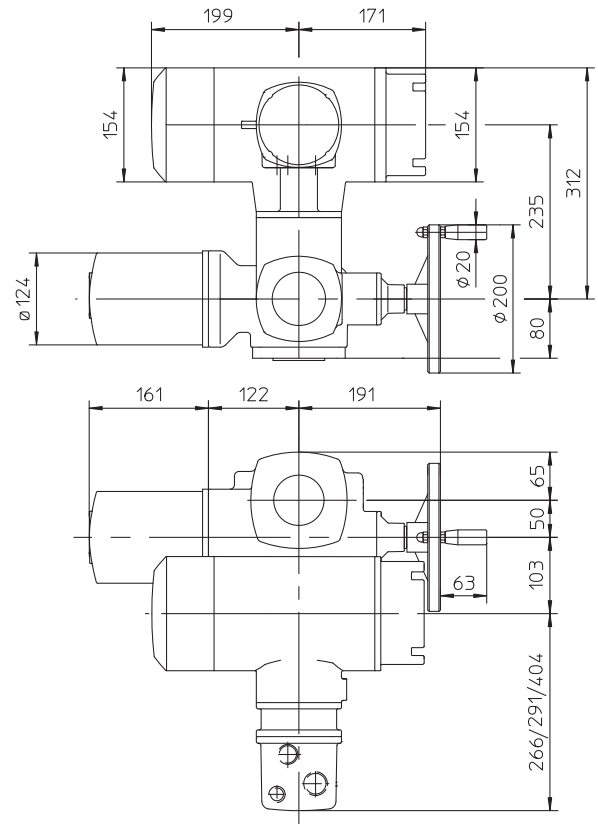

Output drive shaft A, F10

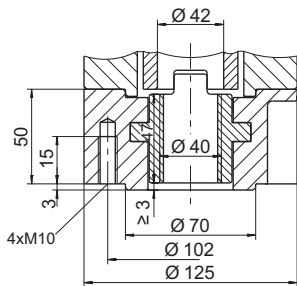

Control DN 200 - 400
Connection A, F10, Tr36x6-LH

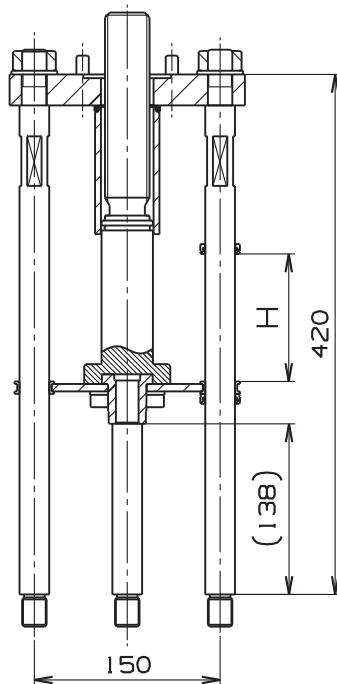

Control DN 500 - 600
Connection A, F10, Tr36x6-LH

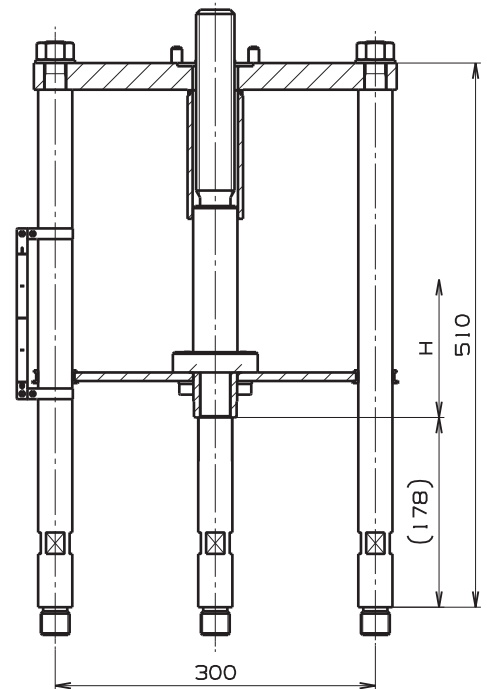

Hand wheels for RV / UV 2x0 SP, RV 2x2 SP

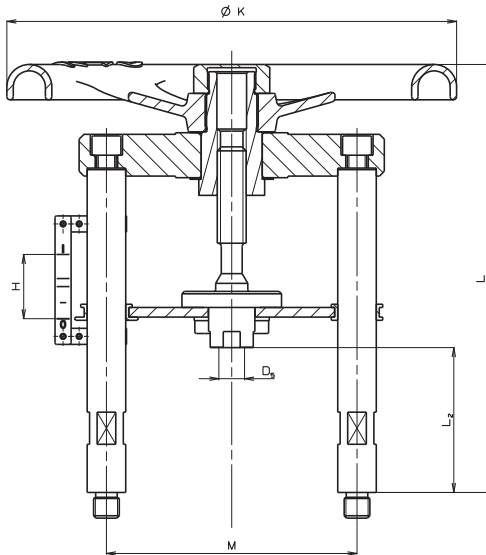

Hand wheel for DN 15 - 150

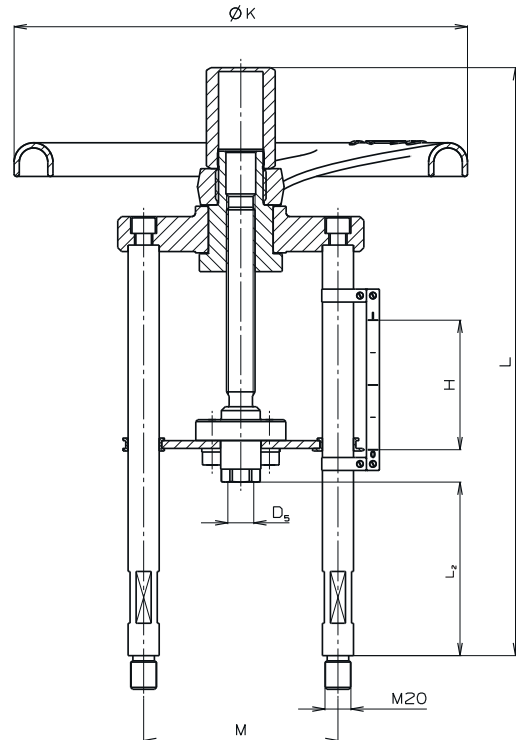

Hand wheel for DN 200 - 400

Dimensions of manual control									
DN	Marking	H [mm]	L [mm]	L ₂ [mm]	ØK [mm]	M [mm]	D _s [mm]	m [kg]	Ordering no. (BOM number)
15	R16	16	209	70	160	140	M10x1	7	S900 0256
20					195				
25					195				
32					195				
40	R20	25	235	90	195	156	M16x1,5	12	S900 0257
50					280				
65					280				
80	R28	40	267	90	280	156	M16x1,5	14,5	S900 0258
100					323				
125	R35	80	454	134	350	150	M20x1,5	15	S900 0259
150									S900 0141
200									S900 0141
250									S900 0141
300									S900 0141
400	100	S900 0235							

Maximal permissible operating pressures ČSN EN 12516-1, resp. ČSN EN 1092-2 [bar]

Material	PN	Temperature [°C]															
		RT ¹⁾²⁾	50	100	150	200	250	300	350	375	400	425	450	475	500	525	550
	10	10.0	10.0	10.0	9.7	9.2	8.7	8.0	---	---	---	---	---	---	---	---	---
	16	16.0	16.0	16.0	15.5	14.7	13.9	12.8	---	---	---	---	---	---	---	---	---
	25	25.0	25.0	25.0	24.3	23.0	21.8	20.0	---	---	---	---	---	---	---	---	---
	40	40.0	40.0	40.0	38.8	36.8	34.8	32.0	---	---	---	---	---	---	---	---	---
Cast steel 1.0619	10	10.0	10.0	9.4	8.9	8.4	7.7	7.0	6.5	6.2	6.0	5.2	3.7	---	---	---	---
	16	16.0	16.0	15.0	14.2	13.4	12.3	11.1	10.4	10.0	9.6	8.3	5.9	---	---	---	---
	25	25.0	25.0	23.4	22.2	21.0	19.2	17.4	16.2	15.6	15.0	13.0	9.2	---	---	---	---
	40	40.0	40.0	37.4	35.5	33.6	30.7	27.8	25.9	25.0	24.0	20.8	14.7	---	---	---	---
Alloyed steel 1.7357	10	10.0	10.0	10.0	10.0	10.0	10.0	10.0	9.3	9.0	8.5	8.2	7.9	7.4	6.2	4.6	2.9
	16	16.0	16.0	16.0	16.0	16.0	16.0	16.0	14.9	14.4	13.57	13.1	12.6	11.8	10.0	7.3	4.7
	25	25.0	25.0	25.0	25.0	25.0	25.0	25.0	23.3	22.4	21.3	20.4	19.7	18.5	15.6	11.5	7.3
	40	40.0	40.0	40.0	40.0	40.0	40.0	40.0	37.3	35.9	34.1	32.7	31.5	29.5	25.0	18.3	11.7
Manganese steel 1.6220	10	10.0	10.0	---	---	---	---	---	---	---	---	---	---	---	---	---	---
	16	16.0	16.0	---	---	---	---	---	---	---	---	---	---	---	---	---	---
	25	25.0	25.0	---	---	---	---	---	---	---	---	---	---	---	---	---	---
	40	40.0	40.0	---	---	---	---	---	---	---	---	---	---	---	---	---	---
Stainless steel 1.4581	10	10.0	10.0	10.0	9.7	9.0	8.5	8.1	7.7	7.5	7.3	7.1	7.0	6.9	6.6	---	---
	16	16.0	16.0	16.0	15.5	14.3	13.7	13.0	12.3	12.0	11.7	11.4	11.2	11.0	10.5	---	---
	25	25.0	25.0	25.0	24.2	22.4	21.4	20.3	19.3	18.7	18.2	17.9	17.5	17.2	16.5	---	---
	40	40.0	40.0	40.0	38.6	35.8	34.2	32.5	30.8	30.0	29.1	28.6	28.0	27.4	26.3	---	---
Stainless steel 1.4308	10	10.0	10.0	9.2	8.1	7.0	6.6	6.2	5.7	5.6	5.4	5.3	5.2	5.0	4.9	4.6	4.4
	16	16.0	16.0	14.8	13.0	11.2	10.5	9.9	9.1	8.9	8.7	8.5	8.2	8.1	7.9	7.3	7.1
	25	25.0	25.0	23.1	20.3	17.5	16.5	15.4	14.3	13.9	13.6	13.2	12.9	12.6	12.3	11.4	11.1
	40	40.0	40.0	37.0	32.5	28.0	26.3	24.6	22.8	22.3	21.7	21.2	20.6	20.2	19.7	18.2	17.7
Stainless steel 1.4309	10	10.0	10.0	9.2	8.3	7.3	6.7	6.2	5.6	---	---	---	---	---	---	---	---
	16	16.0	16.0	14.8	13.2	11.7	10.8	9.9	9.0	---	---	---	---	---	---	---	---
	25	25.0	25.0	23.1	20.7	18.2	16.8	15.4	14.0	---	---	---	---	---	---	---	---
	40	40.0	40.0	37.0	33.0	29.1	26.2	24.6	22.4	---	---	---	---	---	---	---	---

¹⁾ -10°C to 120°C - for EN-JS 1025

²⁾ -10°C to 50°C - for the others

Marking of actuators in type no.

Electric actuator Auma SA 07.2	EAA	DN 15 - 65
Electric actuator Auma SA Ex 07.2	EAB	DN 15 - 65
Electric actuator Auma SAR 07.2	EAC	DN 15 - 65
Electric actuator Auma SAR Ex 07.2	EAD	DN 15 - 65
Electric actuator Auma SA 07.6	EAE	DN 80 - 400
Electric actuator Auma SA Ex 07.6	EAF	DN 80 - 400
Electric actuator Auma SAR 07.6	EAG	DN 80 - 400
Electric actuator Auma SAR Ex 07.6	EAH	DN 80 - 400
Electric actuator Auma SA 10.2	EAI	DN 200 - 600
Electric actuator Auma SAR 10.2	EAJ	DN 200 - 600
Electric actuator Auma SAR Ex 10.2	EAK	DN 200 - 600
Electric actuator Auma SA Ex 10.2	EAL	DN 200 - 600
Hand wheel for DN 15 - 40	R16	
Hand wheel for DN 50 - 65	R20	
Hand wheel for DN 80 - 100	R28	
Hand wheel for DN 125 - 400	R35	



LDM, spol. s r.o.
Litomyšlská 1378
560 02 Česká Třebová
Czech Republic

tel.: +420 465 502 511
fax: +420 465 533 101
e-mail: sale@ldm.cz

LDM, spol. s r.o.
Office Prague
Podolská 50
147 01 Praha 4
Czech Republic

tel.: +420 241 087 360
fax: +420 241 087 192
e-mail: sale@ldm.cz

LDM, spol. s r.o.
Office Ústí nad Labem
Ladova 2548/38
400 11 Ústí nad Labem
- Severní Terasa
Czech Republic

tel.: +420 602 708 257
e-mail: sale@ldm.cz

LDM servis, spol. s r.o.
Litomyšlská 1378
560 02 Česká Třebová
Czech Republic

tel.: +420 465 502 411-3
fax: +420 465 531 010
e-mail: servis@ldm.cz

LDM Bratislava s.r.o.
Mierová 151
821 05 Bratislava
Slovakia

tel.: +421 2 43415027-8
fax: +421 2 43415029
e-mail: ldm@ldm.sk

LDM, Polska Sp. z o.o.
ul. Bednorza 1
40 384 Katowice
Poland

tel.: +48 32 730 56 33
fax: +48 32 730 52 33
mobile: +48 601 354 999
e-mail: ldmpolska@ldm.cz

LDM - Bulgaria - OOD
z. k. Mladost 1
bl. 42, floor 12, app. 57
1784 Sofia
Bulgaria

tel.: +359 2 9746311
fax: +359 2 9746311
mobile: +359 888 925 766
e-mail: ldm.bg@ldmvalves.com

OOO "LDM Promarmatura"
ul. Zarechnaya,
dom. 11 k. 105, of. 206
141435 g.o. Khimki, g. Khimki,
mkr. Novogorsk, Moscow Region
Russia

tel.: +7 495 777 2238
mobile: +7 903 225 4333
e-mail: inforus@ldmvalves.com

TOO "LDM"
Vodokanalnaya 21
101200 Sarañ
Kazakhstan

tel.: +7 7212 566 936
fax: +7 7212 566 936
mobile: +7 701 738 36 79
e-mail: sale@ldm.kz

www.ldmvalves.com

LDM, reserves the right to modify or improve the designs or specifications of such products at any time without notice

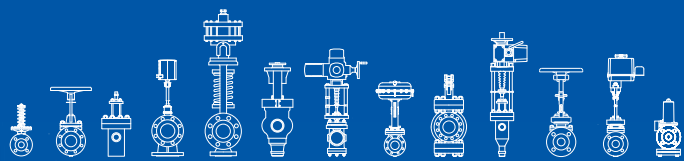
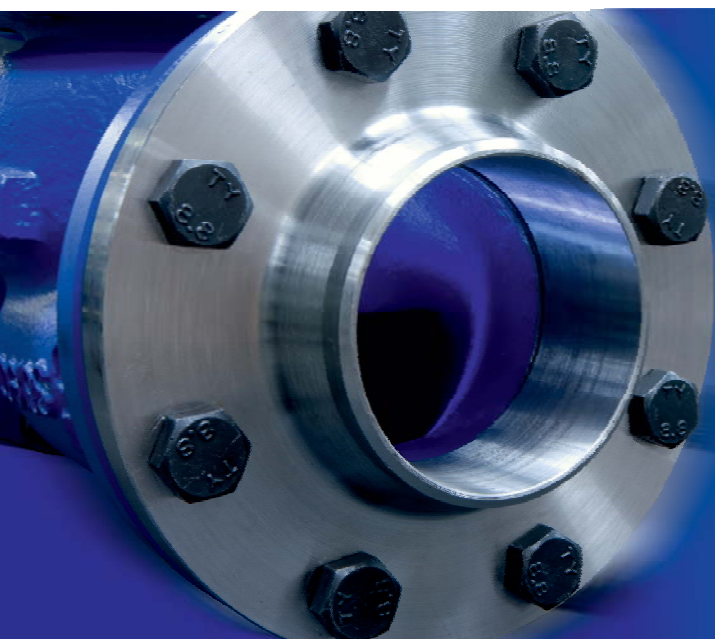

POWER THROUGH IDEAS