	INSTRUCTION FOR INSTALLATION AND MAINTENANCE	UV926 ZV926
	SHUT-OFF/CONTROL GLOBE VALVE CHECK VALVE	PM - 225/18/04/GB

The instructions for installation and maintenance of UV926 and ZV926 valves are binding for users to ensure proper function of valves. The user must keep the rules said here while installation, operation and maintenance. If the usage of the valves is different from mentioned herein, the guarantee terms are not valid any more.

1. TECHNICAL DESCRIPTION AND VALVE FUNCTION

1.1. Description

1.1.1 UV926

The UV926 is single-seat globe valve, designed for shutting-off/control of medium flow. The valve is a yoke type with a non-rotating stem prevented from rotating with a guide, which serves also as indicator of position. The body is forged and connected to the yoke with the bayonet, prevented from rotating with a screw and nut. The valve is equipped with packing, consists of expanded graphite rings.

The trim, with a high wear resistance, consists of the stem with the hard faced plug (made as one piece), and the body seat, also hard faced. The spherical sealing surface of the plug fits to the conical sealing surface of seat, which guarantees a high tightness of the valve.

The valve is controlled with a hand wheel or a multi-turn electric actuator. The stem nut is seated in ball bearings, which minimizes the operating torque (force).

1.1.2 ZV926

The ZV926 is single-seat check valve. The body of valve is forged, closed in upper part by screw stopper. The body-plug sealing is made from expanded graphite.

The trim, with a high wear resistance, consists of the hard faced loose plug and the body seat, also hard faced. The spherical sealing surface of the plug fits to the conical sealing surface of seat, which guarantees a high tightness of the valve.

1.2 Application

1.2.1 UV926

The valves UV926 are suitable for shutting off water, steam and other liquids and gases which are compatible with materials used for the valve body and trim. The medium has to be free of mechanical impurities. If you are not sure of the valve suitability for the given medium, ask the manufacturer's technical department for assistance.

In making decisions on the valve application, the fact, that it is the valve with a high pressure loss coefficient, has to be taken into account. That's why this valve is primarily suitable for applications, where the trim is mostly in the closed position. The permanent operation of partially opened valve with the shut-off characteristic is forbidden.

The valve with control characteristic (the shaped plug) is intended for the rough control of the media flow. The valve can be permanently partially opened, however, the maximum pressure drop is limited to 5 MPa in this case.

1.2.2 ZV926

The valves ZV926 are intended for back flow prevention of water, steam and other liquids and gases which are compatible with materials used for the valve body and trim. The medium has to be free of mechanical impurities. If you are not sure of the valve suitability for the given medium, ask the manufacturer's technical department for assistance.

In making decisions on the valve application, the fact, that it is the valve with a high pressure loss coefficient, has to be taken into account. The valve works automatically, i.e. the plug is forced by back pressure and it's own weight only (in case of AUT execution), respectively by back pressure, it's own weight and force of spring (in case of AUP execution).

1.3 Technical data

Series	UV926		ZV926
Execution	Single-seat shut-off (control) globe valve		Single-seat check valve
Nominal size	DN 10 to 65		
Nominal pressure	PN 63, 100, 160, 250, 320, 400, 630		
Body seat material	Body material + hard metal overlay Stellite 6		
Plug material	1.4923 + hard metal overlay Real 096		
Yoke material	1.0619	1.7357	---
Weld ends connection	Acc. to EN 12627		
Flange ends connection	Acc. to EN 1092-1		
Available types of flanges	Raised face (type B1 and B2); Tongue (type C); Groove (type D); Spigot/male (type E); Recess/female (type F) acc. to EN 1092-1		
Flow characteristic	On-Off; Control		On-Off
Leakage rate	Class A (On-Off characteristic) acc. to EN 12266-1		
	Class D (Control characteristic) acc. to EN 12266-1		---
Packing	Expanded Graphite		

Body material	Temperature range (from -10 °C)
11416	to 400°C
12020	to 350°C
1.0460	to 450°C
15128	to 575°C
1.4571	to 600°C
1.4903	to 600°C
1.5415	to 550°C
1.7335	to 550°C
1.7380	to 600°C
1.7383	to 600°C
1.4541	to 600°C
1.4901	to 650°C
A182 F92	to 650°C
A182 F22	to 600°C
A182 F316	to 650°C

1.4 Dimensions and mass of UV 926 valve with welding ends

DN	H	L ₁	V ₁	V ₂	V ₃	D _{4max}	K	D ₅	D ₆	D ₇	D ₈	a _p	n _p	d _p	m ₁
	mm	mm	mm	mm	mm	mm	mm	mm	mm	mm	mm	mm		mm	kg
10	12	150	33	266	225	36	200	125	102	70	20	14	8	12	5.8
15															
20	16	160	47	298	250	54	250	175	140	100	30	18	8	18	10
25															
32	22	210	66	387	319	70	400	175	140	100	30	18	8	18	21
40															
50	36	250	85	480	401	90	500	175	140	100	30	18	8	18	37
65															

m₁ - approximate mass of valve with weld ends

Dimensions of weld ends according to EN 12627, respective according to customer's choice.

Flange connection on customer's demand only.

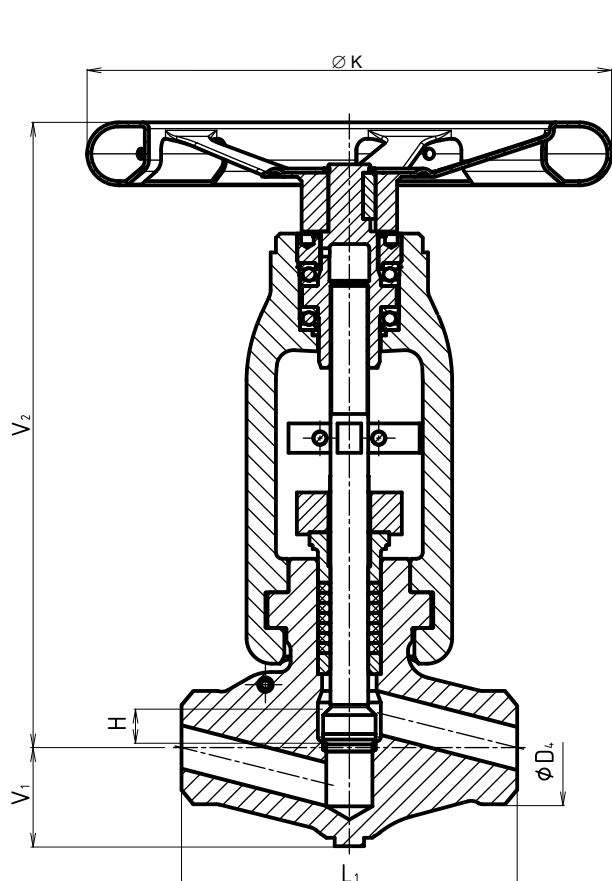

Valve controlled with hand wheel (RXX execution)

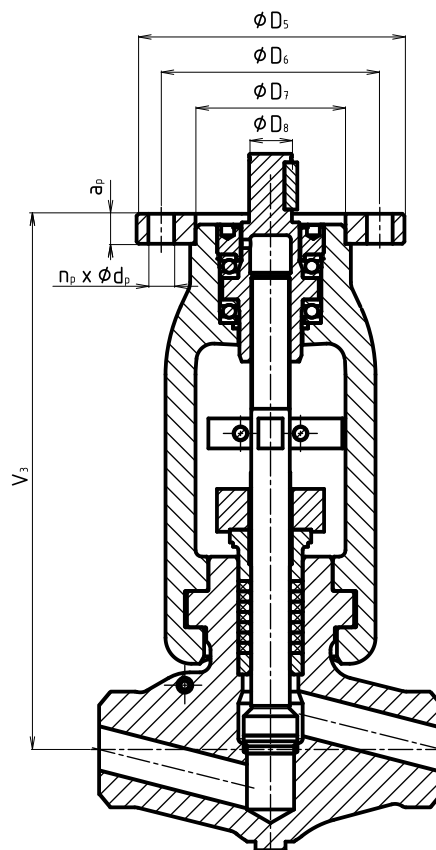

Valve ready for actuator connection (EXX execution)

Torques of UV926 valve

	Tightening torque of packing cover nut	Operating torque of hand wheel
DN 10-15	20Nm	25Nm
DN 20-25	30Nm	55Nm
DN 32-40	70Nm	110Nm
DN 50-65	115Nm	250Nm

1.5 Dimensions and mass of ZV 926 valve with welding ends

DN	L	V	V ₁	D _{4 max}	m ₁
	mm	mm	mm	mm	kg
10	150	82	33	36	2
15					
20	160	98	47	54	4
25					
32	210	128	66	70	9
40					
50	250	154	85	90	15
65					

m₁ - approximate mass of valve with weld ends

Dimensions of weld ends according to EN 12627, respective according to customer's choice.

Flange connection on customer's demand only.

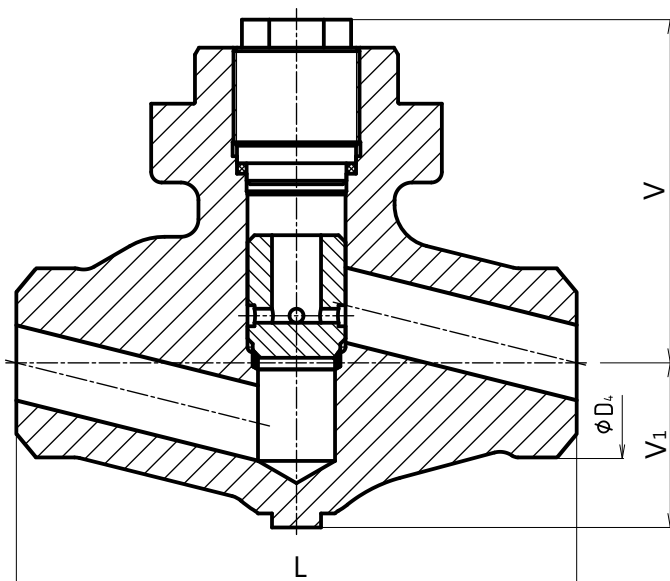

Valve without spring (AUT execution)

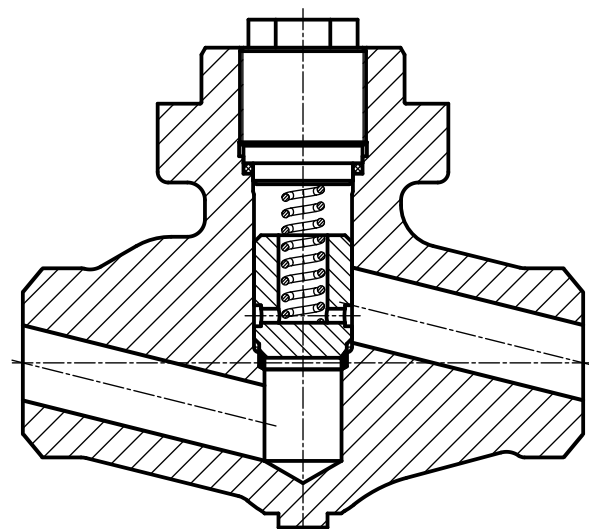

Valve with spring (AUP execution)

Stopper tightening torques of ZV926 valve

	Screw plug
DN 10-15	100Nm
DN 20-25	150Nm
DN 32-40	260Nm
DN 50-65	370Nm

2. INSTALLATION OF THE VALVE INTO PIPELINE

2.1 Preparation before installation

The valves are delivered completely assembled and tested. Prior to the valve installation, it is necessary to compare the data on the valve ID-plate (in case of ZV926 on the stopper) with data from accompanying documents. It is also necessary to verify whether the ID-plate data corresponds to parameters of the pipeline the valve is to be installed in. The valves shall be inspected for mechanical damage or impurities.

Before installing the valve, protect it against damage. In particular protect welding ends, sealing surfaces of flanges and the valve stem. After protective plastic plugs have been removed from the welding ends, it is necessary to properly clean these ends from any preservative agent, i.e., the best just before their welding in the pipeline.

Always purify the pipeline system prior the valve installation.

2.2 Installation into the pipeline

All activities, connected with the valve installation, shall be performed by a worker appropriately qualified, which guarantees good quality execution of works, and thoroughly acquainted with the valve design and this manual.

The UV926 valve with hand wheel can be installed in any position. The UV926 valve with electric actuator can be installed in any position, except the position with actuator under the valve body. For shut-off valve, both directions of flow are possible. For the valve with control plug, the direction of media flow must be in accordance with arrow, marked at valve's body ("under" the plug). It's recommended to insulate the valve body and the pipeline close to valve. On the contrary, the insulation of the valve yoke is prohibited.

The ZV926 AUT (check valve without spring) can be installed in horizontal pipeline with stopper at the top. The ZV926 AUP (check valve with spring) can be installed in any position. The direction of media flow must be in accordance with arrow, marked at valve's body.

The valve installation shall be performed so as to exclude any force effects of the pipeline on the valve. The valve must not serve as a pipeline support. To exclude any thermal deformations of the valve, it is necessary to open it a little before welding. Before welding the valve in the pipeline, thoroughly clean the welding ends from any preservative agent and rub them with sandpaper or wire brush. The pipeline straight piece length upstream and downstream of the valve is recommended min. 6x DN. Use the filler with material corresponding to the valve body and the pipeline materials.

The UV926 valves with shut-off characteristic are able to close the total pressure gradient for both flow directions. However, from the trim lifetime point of view, the manufacturer recommends the flow direction under the plug.

The UV926 valves with control characteristic are designed for the pressure gradient up to 5 MPa. The medium flow direction shall be in accordance with arrow, marked at valve's body ("under" the plug).

Leave enough room to allow for in-line operation, maintenance and repairs. The space above the hand wheel should be larger than the total height of the valve.

At higher operating temperatures of the medium, it is necessary to properly insulate the pipeline and the valve body. On the contrary, the insulation of the valve yoke is prohibited.

2.3 Actuator connection (for the valves controlled with the electric actuator only)

These works can only be executed by the qualified person. It is necessary to observe all the safety regulations related to the electric machines. Furthermore, it is necessary to follow the installation manual containing instructions for operation and maintenance of actuator, published by the manufacturer. The position transmitter and end switches, if supplied, are mounted inside the actuator.

Before wiring, check the actuator's ID-plate data and verify that the supply voltage value or the control signal value corresponds to the required specification.

Considering, that the valve is supplied with actuator as one unit, the basic adjustment of the actuator is performed as well. The actuator switching off in the position "Closed" is realized by the torque switch (so, the valve is really closed tight), while the actuator switching off in the position "Opened" is realized by the position switch.

If the actuator has to be removed from the valve for any reason, it is necessary, after its reinstallation, to check adjustment of above mentioned switches, eventually to readjust them.

The manufacturer is not liable for damages arising from incorrect adjustment of the actuator. You can ask the service organization of the manufacturer to do this job, if necessary.

Select the cable length so as to enable removal of the actuator from the valve without necessity to disconnect the cables from the terminal board.

2.4 Inspection after installation

After installation of the valve into pipeline, it is necessary to perform the pressure test. Check welding or flange connections and the packing/the stopper for leakage.

Furthermore, for UV926 valve, test the function of the valve that has to operate smooth throughout whole stroke. In doing it, perform several strokes. If no defects are detected, the valve is ready for commissioning.

3. VALVE OPERATION

3.1 UV926

The valve controlled with the hand wheel - the hand wheel may heat up during operation. Hence, before using the hand wheel, check its temperature. The personal protective equipment (gloves) must be used in case of an increased temperature of the hand wheel. Turn the hand wheel clockwise to close the valve. The guide, fixed to the stem serves as the indicator of the valve position. The end positions are marked at the yoke.

It is strictly forbidden to attempt to forcibly achieve the valve tightness by using a higher operating torque than specified in Article 1.4. The use of various extension arms, etc., placed on the hand wheel, can destroy the valve.

Attention: While opening or closing the valve using the electric actuator's hand wheel, watch the indicator of the valve position mounted on the valve and be careful while reaching the end positions. In case the valve is controlled with the electric actuator's hand wheel, no electric switches are enabled and there is a danger of the valve or the electric actuator damage

3.2 ZV926

The valve works in fully automatic regime.

4. MAINTENANCE

4.1 Routine maintenance

Veškeré práce spojené s údržbou armatur musí provádět jen pracovník, který má dostatečnou kvalifikaci pro All the works connected with the valve maintenance shall be performed by the appropriately qualified personnel, thoroughly familiarized with the valve design and this manual, which guarantees quality execution of works.

The UV926 valve has been designed with minimum requirements for maintenance. It is not necessary to relubricate the valve in operation. Lubrication of the stem motion thread (Matrix Grease CAS 2 Green) is intended for more than 1,500 full operating cycles, provided that the specified operating conditions are followed. The stem axial force is taken by axial ball bearings (lubricated with Matrix Grease CAS 2 Green) that don't have to be relubricated until the overhaul.

The valve maintenance most commonly consists of dealing with packing leakage (see Article 4.1.1). If the valve leakage appears, a cause can be the quality of seat surface (see Article 4.1.2) or the condition of the motion thread (see Article 4.1.3). To eliminate the valve leakage, we recommend to call for the manufacturer's expert service.

In case of the yoke removal, check, and if required, refill the separating lubricant Gleit-μ HP 505 in contact surfaces of all parts.

4.1.1 Packing- UV926

The packing consists of expanded graphite rings, which are pressed via the packing tube with two screws and nuts. Watch the packing tightness during operation and if required, tighten it up. If the packing tube shoulder reaches the housing due to gradual "run-out" of graphite, refill the packing box with another graphite ring. This can be performed only if the valve is shut down (there must be no pressure in the valve inner space). A back seat is not locked axially, thus the medium leakage could occur, followed by an injury of persons staying in the vicinity of the valve.

In case of emergency, it is possible to replace the packing ring with a cord from the expanded graphite of corresponding square section. This can only be used as temporary solution, until the nearest shutdown when the packing cord has to be replaced with a moulded ring.

Tighten the packing nuts uniformly using the tightening torque specified in Article 1.4 so, that the packing cover is perpendicular to the stem. There must be no gap on any side between the packing cover and tube. Having added the ring, verify smooth running of the stem in the packing by performing several strokes. Inspect the stem visually.

The packing screw/nut threads are lubricated with the Gleit-μ HP 505 lubricant.

4.1.2 Stem (plug) and seat sealing surface – UV926, ZV926

Sealing surfaces of the stem (plug) and the seat gradually get worn out during their life. A defect reveals like the valve leakage. In this case we recommend to ask for the manufacturer's expert service that provide the valve repair (the body seat lapping, eventually replacement of the worn stem for the new one).

4.1.3 Stem motion thread – UV926

In performing the regular valve revision, pay special attention to the most exposed valve parts, i.e., the motion thread of the stem and stem nut. This area must be kept clean and properly lubricated. If necessary, apply the Matrix Grease CAS 2 Green lubricant.

The lubricating ability of the lubricant can decrease during operation, resulting in non-smooth running of the motion thread (thread “seizing”). This will result in excessive wear of the thread accompanied by a reduction of the sealing force and finally can be root of the valve leakage.

If a considerable wear of the stem thread does not appear yet, the problem can be solved by reapplying the above mentioned lubricant. If leakage persists, the thread is excessively worn and the stem and eventually the stem nut must be replaced.

4.1.4 Alternative lubricants

The Gleit- μ HP 505 and Matrix Grease CAS 2 Green lubricants, used by the manufacturer, can be replaced for the other lubricants, with the same or better lubricating ability and thermal resistance. However, it is forbidden to mix two different lubricant types! Prior the replacement, the original lubricant must be properly cleared away!

4.2 Preventive inspections (once a year) – UV926, ZV926

The inspection consists of intimate visual inspection of the valve for mechanical damage.

For the **UV926** extra: If the packing starts to leak during operation, it must be fixed according to Article 4.1.1.

Furthermore, check the correct function of valve by performing several strokes. In carrying out the inspection, close the valve using the tightening torque specified in Article 1.4. The stem must move smoothly in full stroke.

4.3 Overhaul (after 10 years of service or in case of failure) – UV926, ZV926

We recommend to call for the manufacturer's expert service to execute the overhaul.

For the **UV926** valve: The overhaul includes replacement of the stem (with the plug) and relapping of the body seat. The packing rings shall be completely replaced. The packing cover's screws and nuts shall be thoroughly checked and replaced if required. Based on the condition of motion thread, the stem nut may be also replaced. Lubricants shall be refilled. If a functional defect of other parts is found out, these parts shall be replaced. The packing cover's nuts shall be tightened according the table in article 1.4.

For the **ZV926** valve: The overhaul includes replacement of the plug and relapping of the body seat. The sealing of the stopper is replaced and the stopper thread is relubricated. The stopper shall be tightened according the table in article 1.5.

5. SPARE PARTS

The spare parts are not included in the delivery of valves and have to be ordered separately. In ordering, please specify the following data:

- Spare part name
- Valve type number
- Valve serial number (for determination of flange type/welding end geometry)
- Number of pieces

6. TRANSPORTATION AND STORAGE

During transport and storage, the valve must not be exposed to water or placed in environment with relative humidity exceeding 90 %.

With respect to used actuators, the temperature during transport and storing shall be in the range -20 to +55°C. Inlet flanges must be protected with blinds (these are part of delivery).

Suitable tools/devices should be used for valve lifting during the transport and installation. It is necessary to make sure the valve can't be damaged during manipulation and transport.

If the valves are stored for more than 3 years under these conditions, the producer recommends to carry out preventive inspection of the valves.

7. WASTE DISPOSAL

Packaging material and the valves shall be disposed of in the common way such as by handing over to a specialized enterprise for disposal of (body and metal parts - metal waste, other non-metal parts - communal waste).

Complete specification code for UV/ZV926 valve ordering

		XX	XXX	XXX	XXXX	XX	XXX	/	XXX	-	XXX
1. Valve	Shut-off valve	UV									
	Check valve	ZV									
2. Series	Straight flow, forged body		926								
3. Type of actuating	Electric actuator			EXX							
	Hand wheel			RXX							
	Without spring			AUT							
	With spring			AUP							
4. Connection	Flanges with raised face, type B1 (rough)				1						
	Flanges with recess, type F (female)				2						
	Flanges with raised face, type B2 (fine)				3						
	Weld ends				4						
	Flanges with spigot, type E (male)				5						
	Flanges with tongue, type C				6						
	Flanges with groove, type D				7						
	Other connection on request				9						
5. Body material	Material 11416 (-10 to 400°C)				A						
	Material 12020 (-10 to 350°C)				B						
	Material 15128 (-10 to 575°C)				C						
	Material 1.0460 (-10 to 450°C)				D						
	Material 1.4571 (-10 to 600°C)				E						
	Material 1.4903 (-10 to 600°C)				F						
	Material 1.5415 (-10 to 550°C)				G						
	Material 1.7335 (-10 to 550°C)				H						
	Material 1.7380 (-10 to 600°C)				I						
	Material 1.7383 (-10 to 600°C)				J						
	Material 1.4541 (-10 to 600°C)				K						
	Material 1.4901 (-10 to 650°C)				L						
	Material A182 F92 (-10 to 650°C)				M						
	Material A182 F22 (-10 to 600°C)				N						
	Material A182 F316 (-10 to 650°C)				O						
Other material on request				9							
6. Packing	Expanded graphite				5						
7. Execution	Standard				0						
8. Plug type	Shut-off					0					
	Control					1					
9. Accessories	No accessories					0					
10. Nominal pressure	PN 63						063				
	PN 100						100				
	PN 160						160				
	PN 250						250				
	PN 320						320				
	PN 400						400				
	PN 630						630				
	Operating parameters						PS-				
11. Operating temperature °C	Acc. to operating conditions/material selection							/	XXX		
12. Nominal diameter	DN									-	XXX

Ordering code example:

UV926 R25 4B50 00 063/350-020, weld ends acc. to EN 12627-2-DN20, pipe size 26,9 x 2,3

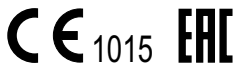

ADDRESS OF FACTORY

LDM, spol. s r.o.
Litomyšlská 1378
560 02 Česká Třebová
Czech Republic

tel.: +420 465 502 511
fax: +420 465 533 101
E-mail: sale@ldm.cz
<http://www.ldmvalves.com>

REGIONAL OFFICES

LDM, spol. s r.o.
Office in Prague
Podolská 50
147 01 Praha 4
Czech Republic

tel.: +420 241087360
fax: +420 241087192
E-mail: tomas.suchanek@ldm.cz

LDM, spol. s r.o.
Office in Ústí nad Labem
Ladova 2548/38
400 11 Ústí nad Labem - Severní Terasa
Czech Republic

tel.: +420 602708257
E-mail: tomas.kriz@ldm.cz

SERVICE ORGANIZATION

LDM servis, spol. s r.o.
Litomyšlská 1378
560 02 Česká Třebová
Czech Republic

tel: +420 465502411-13
fax: +420 465531010
E-mail: servis@ldm.cz

LDM SUBSIDIARIES ABROAD

OOO "LDM Promarmatura"
Jubilejnyi prospekt, dom.6a, of. 601
141407 Khimki
Moscow Region
Russia

tel.: +7 495 7772238
fax: +7 495 7772238
mobile: +7 9032254333
e-mail: inforus@ldmvalves.com

TOO "LDM"
Shakirova 33/1, kab. 103
100012 Karaganda
Kazachstan

tel.: +7 7212566936
fax: +7 7212566936
mobile: +7 7017383679
e-mail: sale@ldm.kz

LDM, Bratislava s.r.o.
Mierová 151
821 05 Bratislava
Slovakia

tel: +421 243415027-8
fax: +421 243415029
E-mail: ldm@ldm.sk
<http://www.ldm.sk>

LDM Armaturen GmbH
Wupperweg 21
D-51789 Lindlar
Deutschland

tel: +49 2266 440333
fax: +49 2266 440372
mobile: +49 1772960469
E-mail: ldmarmaturen@ldmvalves.com

LDM, Polska Sp. z o.o.
ul. Bednorza 1
40-384 Katowice
Polska

tel: +48 327305633
fax: +48 327305233
mobile: +48 601354999
E-mail: ldmpolska@ldm.cz

LDM Bulgaria Ltd.
z.k.Mladost 1
bl.42, floor 12, app.57
1784 Sofia
Bulgaria

tel: +359 2 9746311
fax: +359 2 8771344
mobile: +359 888925766
E-mail: ldm.bg@ldmvalves.com

www.ldmvalves.com

LDM, spol. s r.o. reserves the right to modify or improve the designs or specifications of such products at any time without notice
Guarantee and after guarantee service provided.